

BH3-V

Peristaltic dosing pumps for discontinuous use

The BH series is a range of peristaltic dosing pumps with adjustable flow. They are designed for discontinuous use.

GENERAL FEATURES

- Max Flow rate: 100 l/h .
- Flow rate adjustment: 10 – 100%.
- Max working pressure 1,5 bar.
- Power supply: 90-260 V standard 50/60 Hz.
- Wall mount configuration.
- Tubing available in santoprene, silicone norprene or tygon.
- Accessories: supplied with 4 metre suction/discharge tubing.
- Supplied without injection valve or foot valve.



ACCESSORY KIT OPTIONS

Standard Kit (suitable for most water treatment applications)

PVC/FPM injection valve, PP/FPM foot filter, 2m each of PVC suction & LDPE discharge tubing.

'Brightener' Kit

Nickel plated brass/FPM injection valve, SS foot filter, 2m each of PVC suction & LDPE discharge tubing.

Detergent KIT (suitable for use with detergents)

PP/EPDM injection valve with 90° hose nipple, SS foot filter, 2m each of PVC suction & LDPE discharge tubing.



TECHNICAL FEATURES

Version	Flow Rate l/h (US GAL/h)	Pressure bar (psi)	Connections
1001	10/100 (26.41)	1,5 (21,7)	10x14

CODES

BH NORPRENE	BH SILICONE	BH SANTOPRENE	BH TYGON
PBH42305P6	PBH4230560	PBH4230564	PBH423052F

DIMENSIONS (MM)

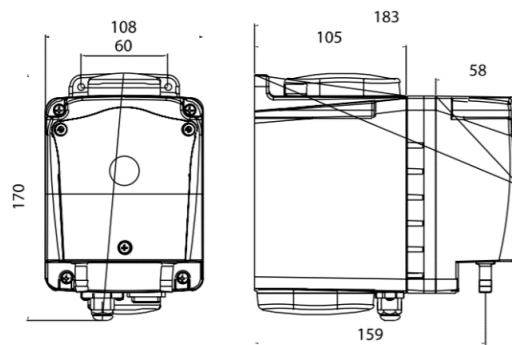

BH3-V SERIES

Peristaltic dosing pumps