

TWINPOOL PDE

Dosing and regulation system for two parameters

The TwinPool is a compact, easy-to-use equipment consisting of two dosing pumps and two parameters controllers designed to measure pH, Redox plus the temperature. Mainly conceived for pool's industry, the dosing pumps are available either in peristaltic and solenoid versions.

GENERAL FEATURES

- Backlighted graphic display, 5 keys keypad,
- Manual dosing (ON-OFF) 0 ÷ 120 pulses / minute
- Proportional dosing by self-regulation of the stroke frequency.
- Flow rate up to 5 l/h and pressure up to 6 bar.
- Measures available: pH-Rx.
- Measurement range:
 - pH: 0 ÷ 14
 - Redox: - 1000 / + 1400 mV
 - Temperature 0 – 100 °C (PT100)
- Hysteresis.
- Activation delay when switched on.
- 3 programming menus: set-point, calibration, settings.
- 3 relays completely selectable: on timer mode (weekly/daily) or as an additional set-point (including the temperature).
- 1 additional relay dedicated to alarm signals
- 4–20mA output fully programmable.
- Inputs: level probes; flow sensor; PT100 probe; proximity switch
- Over dosing alarm.
- Power supply: 230V 50–60Hz*;
- PVDF Pump head
 - Seals: FPM
 - Valves: Ceramic.
- Supplied with complete installation kit:
 - Suction hose: PVC Cristal®
 - Discharge hose: Poliethylene.



PP STANDARD KIT

All TwinPool PDE are supplied with a standard kit made up of PP injection valve, PP foot filter, PVC suction tube and PE discharge tube.



* different configurations available upon request

** other power supplies available on request



TECHNICAL FEATURES

Version	Flow Rate l/h (US GI/ h)	Max Pressure Bar - PSI	Frquency [imp/1']	Standard Pow er Supply (Volts -Hz)	Power consumption (Watts)	Net Weight (Kg)
0206	2 (0,53)	6 (87)	120	230V - 50-60 Hz	65	3,5
0505	5 (1,52)	5 (72)	120	230V - 50-60 Hz	65	3,5

CODES

TwinPool pH-Rx	
Setpoint = 7,2 pH	Dosing mode: ACID
Setpoint = 700mV	Dosing mode: OXIDANT

pH Rx	Version
CXB8010101	0206
CXB4000402	0301

PRESSURE-FLOWRATE DIAGRAM

Pressione (bar) – Portata (l/h)
Pressure (bar) – Flow Rate (l/h) Chart

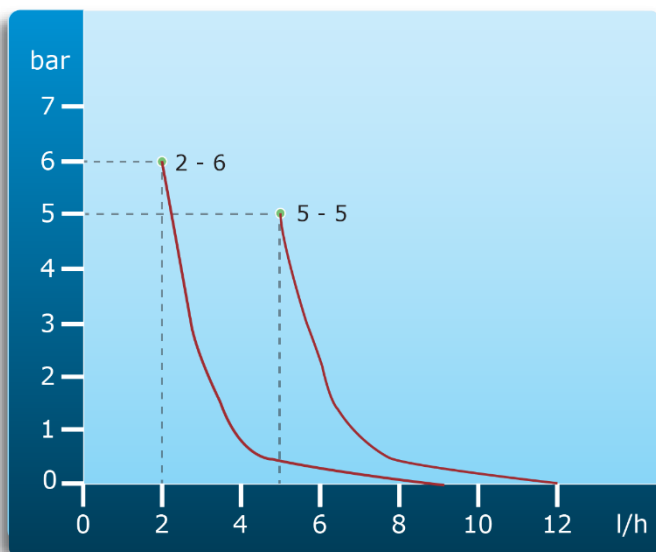

DIMENSIONS (MM)

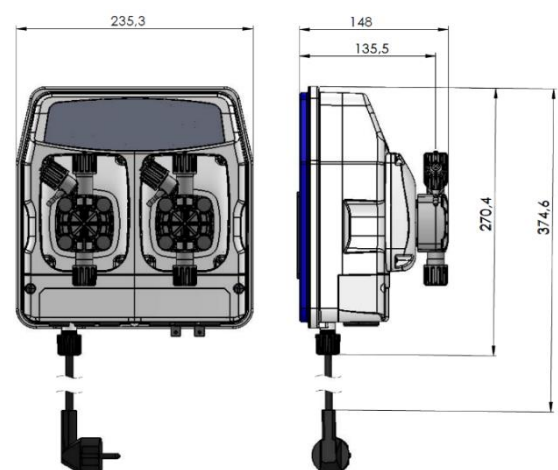

TWINPOOL SERIES

Solenoid dosing pumps