

# OPERATING MANUAL

## HD51.3D... series

Ultrasonic anemometers



EN  
V3.1



## Contents

<b>1</b>	<b>Introduction .....</b>	<b>3</b>
1.1	Models .....	4
<b>2</b>	<b>Technical specifications .....</b>	<b>5</b>
<b>3</b>	<b>Description .....</b>	<b>8</b>
<b>4</b>	<b>Wind speed and direction measurement .....</b>	<b>9</b>
4.1	Measurement compensation with compass and tilt angles .....	10
<b>5</b>	<b>Installation .....</b>	<b>11</b>
5.1	Alignment of the instrument.....	12
5.2	Electrical Connections.....	13
5.2.1	RS232 connection .....	14
5.2.2	RS485 connection .....	14
5.2.3	RS422 connection .....	15
5.2.4	Analog outputs Connection.....	16
5.2.5	Heating connection .....	16
5.2.6	Auxiliary RS485 output connection .....	17
5.2.7	RS52 cable connection.....	17
5.3	Serial output protocol.....	18
<b>6</b>	<b>Configuration.....</b>	<b>19</b>
6.1	Serial Commands .....	19
<b>7</b>	<b>RS232 ASCII proprietary mode .....</b>	<b>31</b>
<b>8</b>	<b>RS485 ASCII proprietary mode .....</b>	<b>32</b>
<b>9</b>	<b>NMEA mode .....</b>	<b>33</b>
<b>10</b>	<b>Modbus-RTU mode.....</b>	<b>35</b>
<b>11</b>	<b>Maintenance .....</b>	<b>37</b>
<b>12</b>	<b>Instrument storage .....</b>	<b>37</b>
<b>13</b>	<b>Safety instructions .....</b>	<b>37</b>
<b>14</b>	<b>Accessories ordering codes .....</b>	<b>38</b>

## 1 Introduction

The instruments of the series **HD51.3D...** are 2-axis ultrasonic static anemometers. In addition to the measurements of wind speed and direction, they also provide the U-V Cartesian components of wind speed and the Wind Gust values. The average of wind speed and direction over a period configurable up to 10 minutes is calculated.

Versions with housing in technopolymer or in anodized aluminum alloy with anti-corrosion coating which allows the instrument to be used even in a particularly aggressive atmosphere (e.g., marine environment) are available.

The versions with housing in technopolymer can optionally be equipped with an integrated **heater**, in order to prevent the accumulation of snow and ice formation, allowing accurate measurements in all environmental conditions.

The versions with housing in anodized aluminum alloy are always equipped with an **enhanced heater**, for rapid defrosting.

The anemometers can optionally integrate the barometric pressure measurement. The versions with housing in technopolymer can optionally also integrate the temperature, relative humidity and global solar radiation measurements, making the instrument a compact and light meteorological station.

Available outputs:

- **RS232, RS485** and **RS422** isolated serial outputs with **NMEA** and **Modbus-RTU** standard protocols and ASCII proprietary protocol.
- Two analog outputs, for wind speed and direction or for velocity U-V cartesian components, which are factory-configurable within 4÷20 mA (standard), 0÷1 V, 0÷5 V or 0÷10 V (**to be specified when ordering**).

Mounting on  $\varnothing$  40 mm mast. The optional function of detecting the orientation (**compass**) and **tilt angles** allows the spatial orientation of the instrument to be determined at any time, allowing installation on mobile vehicles (for example boats) or, in the case of fixed installations, the automatic correction of both a possible misalignment with respect to the vertical axis and an imperfect orientation of the instrument towards the North.

The high immunity to electromagnetic disturbances makes the anemometer suitable for measurements in electrically noisy environments (e.g., industrial environments, wind farms, etc.).

All instrument sensors are factory-calibrated and do not require additional interventions of the user (field calibration is not required).

The absence of moving parts minimizes the instrument maintenance.

The anemometers satisfy the requirements of the following standards:

- **MIL-STD-810G Method 509.6** and **EN ISO 9227:2017** (salt fog anti-corrosion test)
- **MIL-STD-810F Method 521.2** (anti-icing/freezing rain test) – Only versions with housing in anodized aluminum alloy
- **EN 60945:2002 Sect. 8.7 / EN 60068-2-6:2008 / IEC 60068-2-6:2007** (vibration resistance test) – Only versions with housing in anodized aluminum alloy

### 1.1 Models

The table below shows the optional features of the various models of the series.

Model	OPTIONS						
	Barom. pressure	R.H. + Temp.	Global solar radiation	Heating	Compass + Tilt	Bird spikes	Analog outputs
<b>Models with housing in technopolymer</b>							
HD51.3D[K][A][R][V...]				Option <b>R</b>	Option <b>A</b>	Option <b>K</b>	4...20 mA if not specified  Options <b>V</b> : 0...10 V <b>V1</b> : 0...1 V <b>V5</b> : 0...5 V
HD51.3D4[K][A][R][V...]	√						
HD51.3DP[A][R][V...]			√				
HD51.3DP4[A][R][V...]	√		√				
HD51.3D17[K][A][R][V...]		√					
HD51.3D147[K][A][R][V...]	√	√					
HD51.3DP17[A][R][V...]		√	√				
HD51.3DP147[A][R][V...]	√	√	√				
<b>Models with housing in anodized aluminum alloy</b>							
HD51.3D[K][A]R[V...]-AL				√	Option <b>A</b>	Option <b>K</b>	4...20 mA if not specified  Options <b>V</b> : 0...10 V <b>V1</b> : 0...1 V <b>V5</b> : 0...5 V
HD51.3D4[K][A]R[V...]-AL	√			√			

## 2 Technical specifications

	<b>Models in technopolymer HD51.3D[P][1][4][7][A][R]</b>	<b>Models in aluminum alloy HD51.3D[4][A]R-AL</b>
<b>Wind speed</b>		
Sensor	Ultrasounds	
Measuring range	0...85 m/s (versions without T/RH) 0...75 m/s (versions with T/RH)	0...80 m/s
Resolution	0.01 m/s	
Accuracy	± 0.2 m/s or ± 2% of measure, the greatest (0...65 m/s) ± 3% of measure (> 65 m/s)	
<b>Wind direction</b>		
Sensor	Ultrasounds	
Measuring range	0...359.9°. In order to avoid oscillations of the analog output around 0°, the extended range 0...539.9° can be set.	
Resolution	0.1°	
Accuracy	± 2° RMSE (wind speed > 2 m/s)	
<b>Temperature</b> (only models in technopolymer, option <b>17</b> is required)		
Sensor	Pt100	-
Measuring range	-40...+70 °C	-
Resolution	0.1 °C	-
Accuracy	± 0.15 °C ± 0.1% of measure	-
<b>Relative humidity</b> (only models in technopolymer, option <b>17</b> is required)		
Sensor	Capacitive	-
Measuring range	0...100%RH	-
Resolution	0.1%	-
Accuracy (@ T = 15...35 °C)	± 1.5%RH (0...90%RH), ± 2%RH (remaining range)	-
Accuracy (@ T = -40...+70 °C)	± (1.5 + 1.5% of measure )%RH	-
<b>Barometric Pressure</b> (option <b>4</b> is required)		
Sensor	Piezoresistive	
Measuring range	300...1100 hPa	
Resolution	0.1 hPa	
Accuracy	± 0.5 hPa (700...1100 hPa) @ 20 °C ± 1 hPa (500...1100 hPa) / ± 1.5 hPa (300...500 hPa) @ T=(0...60 °C)	
Long-term stability	± 1 hPa/year	
<b>Global solar radiation</b> (only models in technopolymer, option <b>P</b> is required)		
Sensor	Thermopile	-
Measuring range	0...2000 W/m <sup>2</sup>	-
Resolution	1 W/m <sup>2</sup>	-
Accuracy	Class C pyranometer according to ISO 9060:2018	-
<b>Compass + Tilt angles</b> (option <b>A</b> is required)		
Resolution	0.05°	
Accuracy	± 1°	
<b>Heating</b> (option <b>R</b> is required, always included in the models in aluminum alloy)		
Heater power supply	24 Vdc ± 10%	
Heater power consumption	20 W	93 W

<b>General features</b>		
Instrument power supply (excluding heater)	12...30 Vdc (15...30 Vdc for 0...10 V analog output, if available)	
Instrument power consumption (excluding heater)	60 mA @ 24 Vdc	
Serial outputs	Isolated RS232, RS485 and RS422	
Communication protocols	NMEA, Modbus-RTU, ASCII proprietary	
Analog outputs	2 analog outputs, for wind speed and direction or for velocity U-V cartesian components. Output 4...20 mA standard (max. load 500 Ω), on request 0...1 V, 0...5 V or 0...10 V Analog outputs updating rate 4 Hz The outputs are isolated from the power supply	
Measurement interval	From 250 ms to 1 s	
Wind speed averaging interval	Configurable from 1 s to 10 min	
Wind Gust calculation interval	Configurable from 1 s to 10 min	
Electrical connection	19-pole M23 male connector	
Operating temperature	-40...+70 °C (models with housing in technopolymer) -50...+70 °C (models with housing in aluminum alloy)	
Protection degree	IP 66	
Anti-corrosion test	MIL-STD-810G Method 509.6 (48 hours of exposure + 48 hours of drying) EN ISO 9227:2017	
Anti-icing/freezing rain test	-	MIL-STD-810F Method 521.2
Vibration resistance test	-	EN 60945:2002 Sect. 8.7 EN 60068-2-6:2008 IEC 60068-2-6:2007
Survival speed	90 m/s	100 m/s
Weight	640 g approx. (versions without T/RH) 1 kg approx. (versions with T/RH)	1.4 kg approx.
Housing	ASA with aluminum and AISI 316 metal parts	Anodized aluminum alloy and AISI 316
Installation	on mast Ø 40 mm external and Ø 36 mm internal	

**Dimensions** (mm)

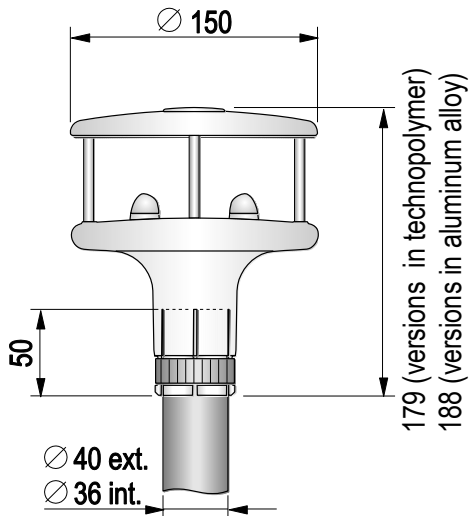

**HD51.3D[4][A][R]**  
**HD51.3D[4]R-AL**

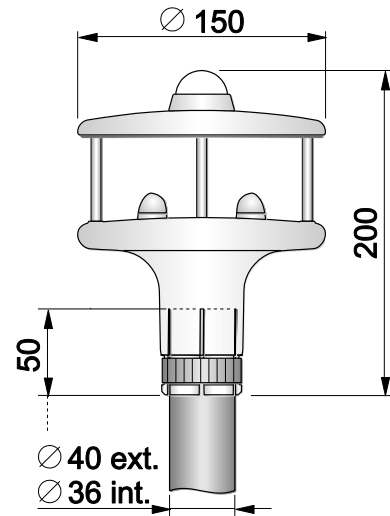

**HD51.3DP[4][A][R]**

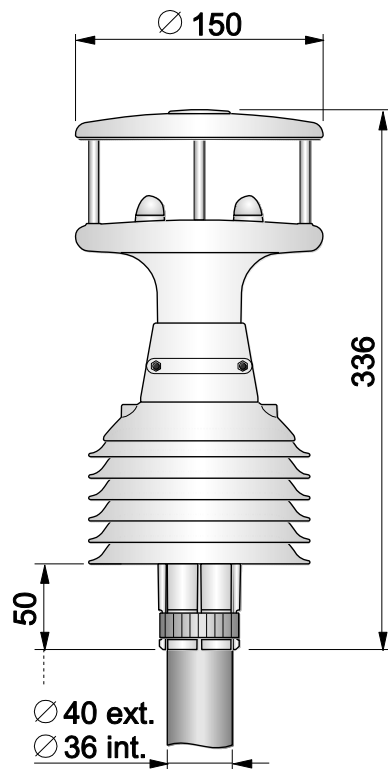

**HD51.3D1[4]7[A][R]**

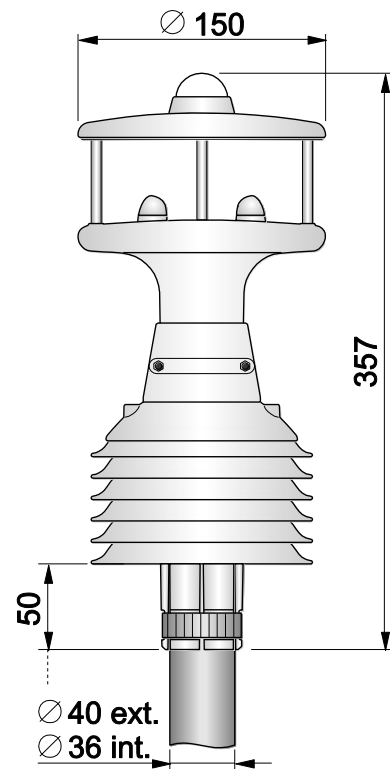

**HD51.3DP1[4]7[A][R]**

### 3 Description

#### Basic versions

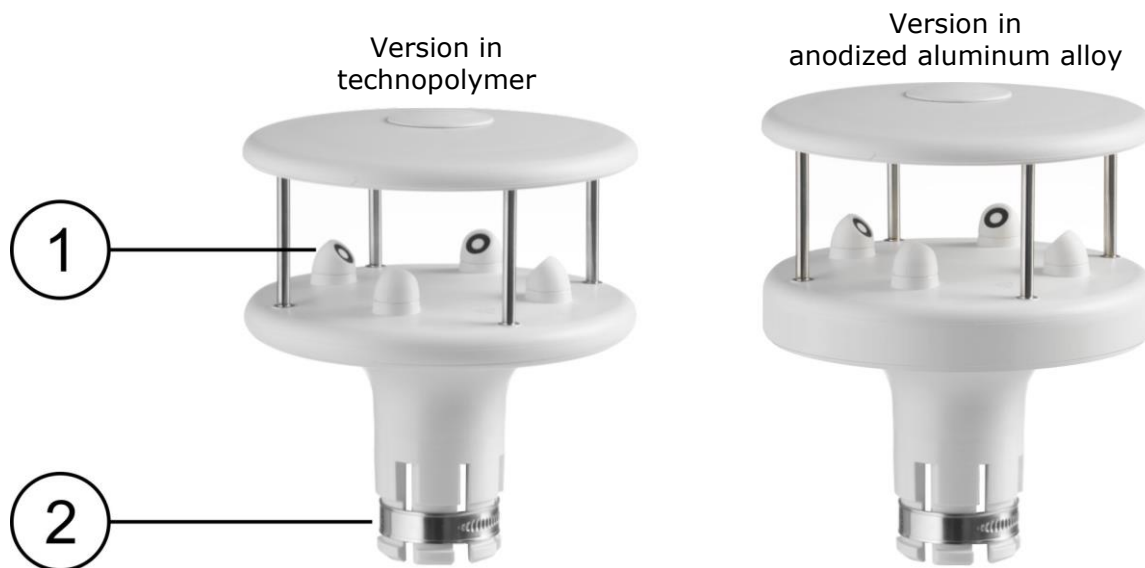

#### Versions with optional measuring sensors (only versions in technopolymer)



1. Ultrasonic sensors for the measurement of wind speed and direction
2. Mast fixing clamp
3. Solar radiation sensor
4. Temperature and relative humidity sensors with solar radiations protection shield



## 4 Wind speed and direction measurement

Wind speed and direction are determined by measuring the time taken by ultrasonic pulses to cover the distance from the transducer that generates the pulse to the receiving transducer.

The instrument uses 2 pairs of transducers oriented along two orthogonal axes. Detecting the wind speed along two axes allows determining not only the intensity but also the wind direction.

The instrument measures the travel time of the ultrasonic pulse between the two transducers of the same pair in both directions. The travel times in the two opposed directions are defined as  $t_A$  (forward direction time) and  $t_R$  (reverse direction time).

If wind speed is zero,  $t_A$  and  $t_R$  values are the same. In the presence of wind, one of the two time values is greater than the other and the comparison between the two time values allows determining the direction and the intensity of the wind.

Measuring the travel time in both directions allows cancelling the dependence of the transmission speed of ultrasounds in the air from the environmental conditions of temperature, humidity and barometric pressure.

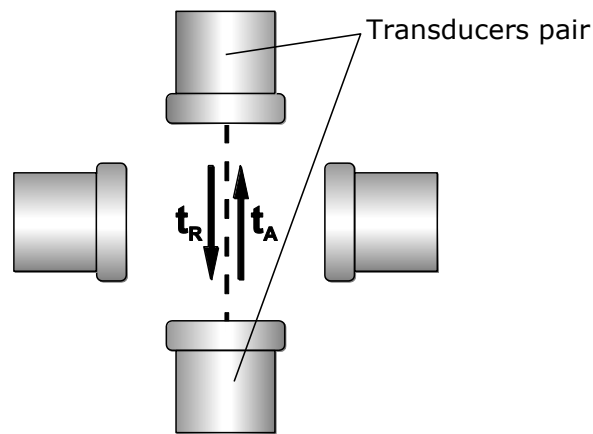

The travel times of the ultrasonic pulses are given by:

$$t_A = \frac{D}{C + V_w} \quad t_R = \frac{D}{C - V_w}$$

Where:

**D** = Distance between the two transducers of the same pair

**C** = Sound speed

**V<sub>w</sub>** = Component of wind speed along the measurement axis

Measuring the two travel times allows determining the wind speed component:

$$V_w = \frac{D}{2} \cdot \left( \frac{1}{t_A} - \frac{1}{t_R} \right)$$

The wind speed components are given by convention along two Cartesian axes called **U** and **V**. The U axis is the axis from West to East, while the V axis is the axis from South to North.

#### 4.1 Measurement compensation with compass and tilt angles

For an accurate measurement, the anemometer must be correctly oriented with respect to the North and must be installed in an exactly vertical position. In the models equipped with compass and tilt angles detection (option **A** in the instrument code), the misalignment with respect to the North and the vertical axis is automatically compensated by the instrument, allowing an accurate measurement whatever the position of the instrument.

The instrument detects two tilt angles:

**Tilt\_X**: tilt of the instrument X axis

**Tilt\_Y**: tilt of the instrument Y axis

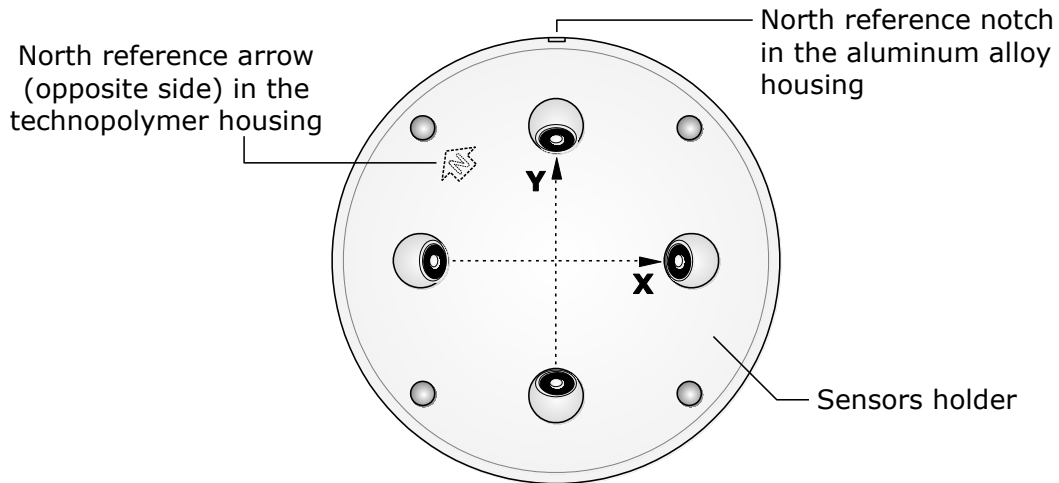

The tilts are considered with respect to a plane parallel to the ground.

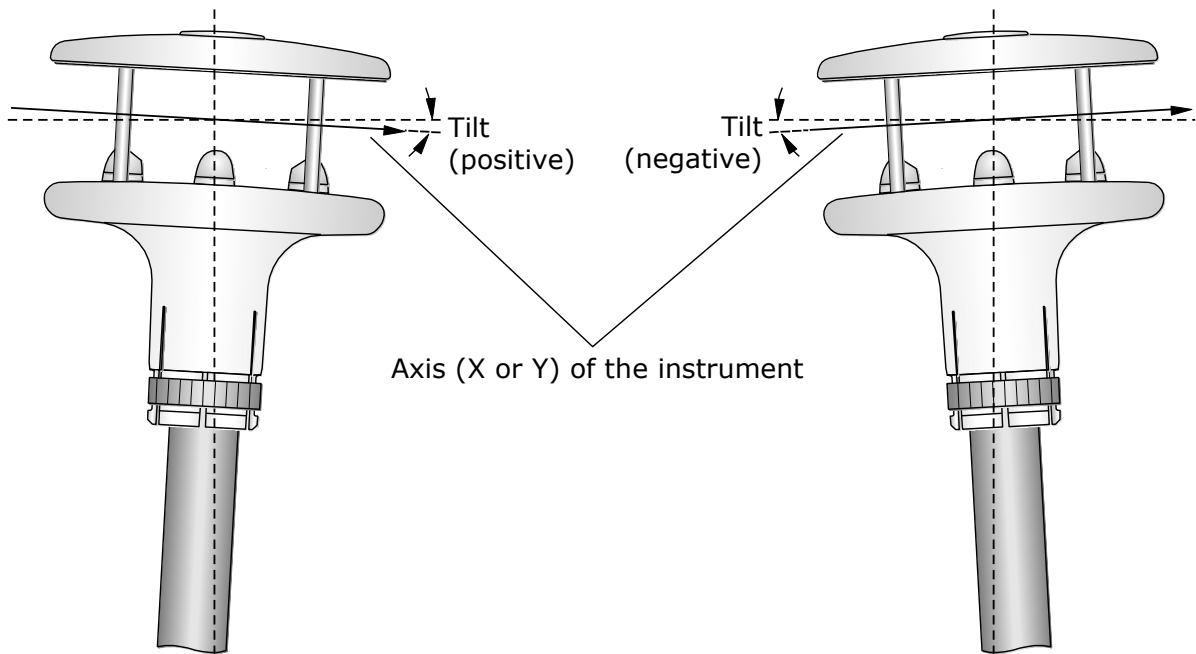

For fixed installations with particular application needs, the compensation of the measurement with compass and tilt angles can be disabled by the user. In this case, the information relating to the compass and the Tilt angles are still available to help positioning the instrument correctly.

## 5 Installation

To install the instrument, pass the connection cable inside the support mast and connect the 19-pole M23 female connector of the cable to the 19-pole M23 male connector situated at the bottom of the instrument. Ensure connection stability by tightening the connector external nut.

Align the instrument (see par. 5.1), then fix it on the support mast by tightening the cable tie at the bottom of the instrument.

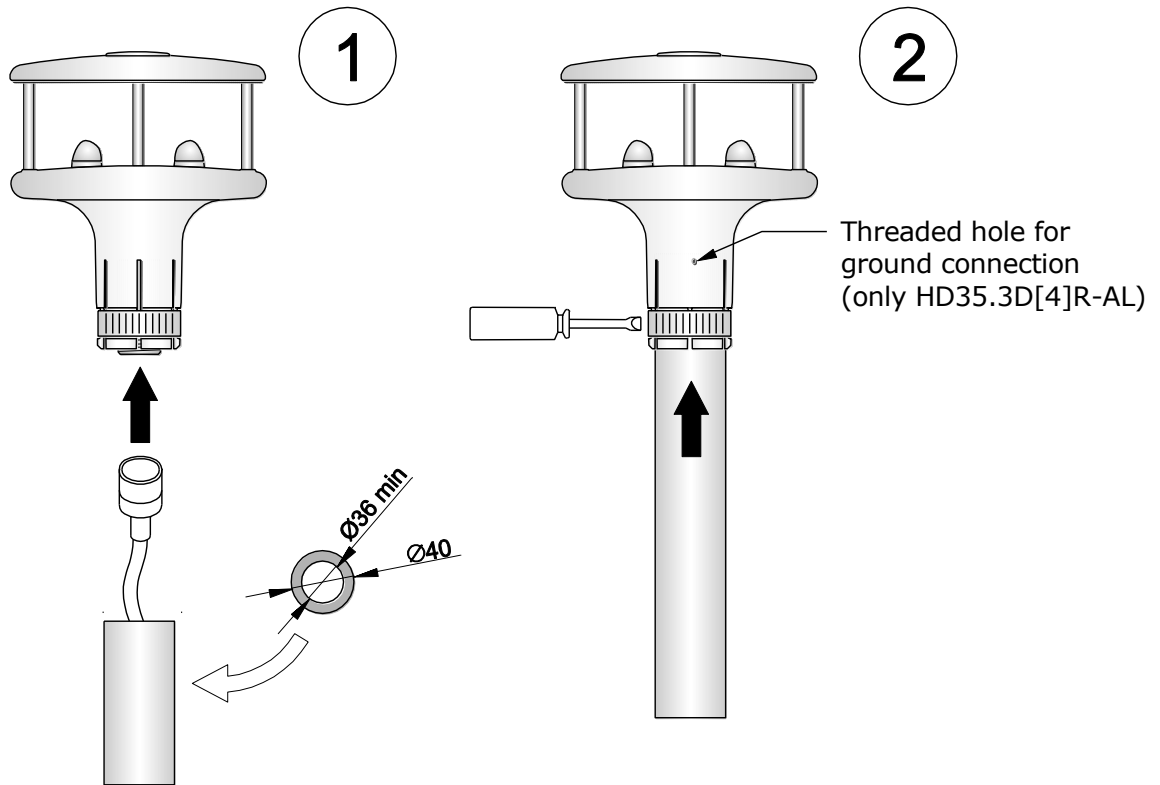

The support mast, having 40 mm maximum outer diameter and 36 mm minimum inner diameter, should be positioned on a stable surface and must be connected to ground.

**The HD54.3D[4]R-AL model must be connected to ground by means of the threaded hole on the instrument body (see the figure above). Insert the cable lug of the ground cable into the fixing screw and tighten the screw to the instrument body.**

The instrument should be installed vertically (the models with the measurement of the tilt angles allows compensating a possible misalignment with respect to the vertical axis) and in an open area, far from obstructions located in the vicinity that might alter the natural air flow. Any close objects (such as buildings, trees, pylons, etc.) should be at a distance equal to at least ten times their height.

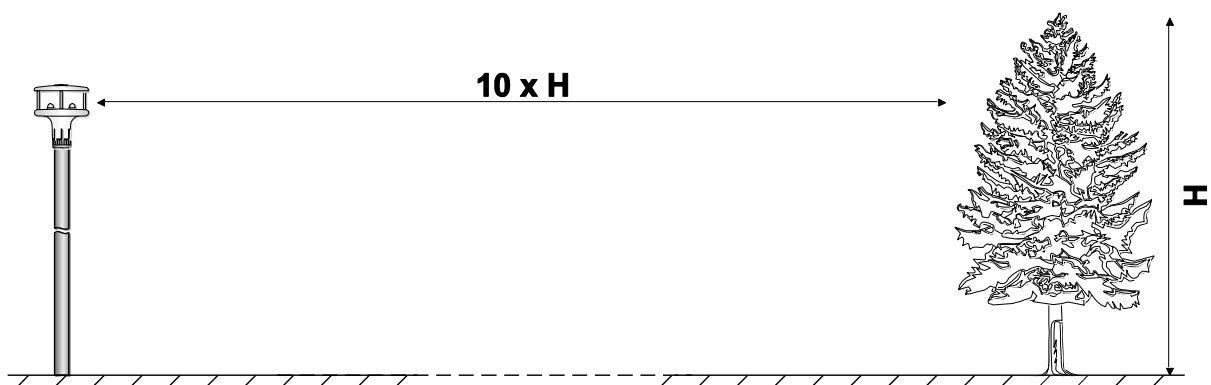

In the presence of close objects, it is advisable to place the instrument at a height of 10 m.

If the instrument is installed on a building, the height of the instrument should be at least 1.5 times the minimum value between the height of the building and the roof longest diagonal.

### 5.1 Alignment of the instrument

If the instrument is equipped with compass (option **A** in the instrument code), wind speed and direction measurements are automatically compensated and referred to **magnetic North**, even if alignment to North is not performed. This allows obtaining accurate measurements even in case of mobile installations. It is possible to set in the instrument (serial command **cx**) a **magnetic declination** value (angular difference between geographical north and magnetic north which depends on the area where the instrument is installed) allowing the measurements to be referred to **geographical North**.

If the instrument is not equipped with compass (or the compensation performed by the sensor is disabled), it is necessary to align the instrument during installation. The housing is provided with a reference to facilitate the alignment: an arrow at the bottom of the ultrasonic sensors supporting plate for versions with housing in technopolymer, two notches on the side for versions with housing in aluminum alloy. The reference must be aligned with the **geographical North**. If a magnetic compass is used for alignment, take into account the **magnetic declination** of the area where the instrument is installed.

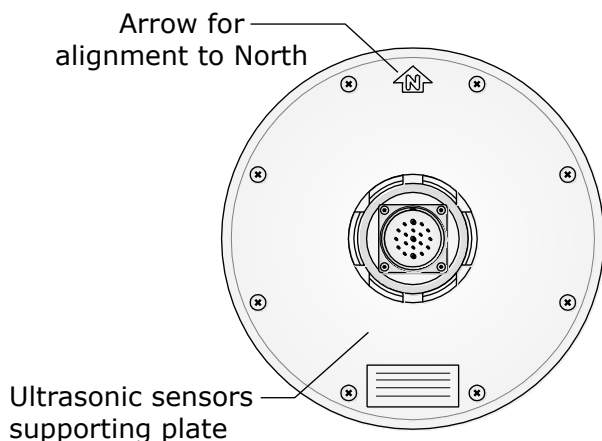

**Housing in technopolymer**

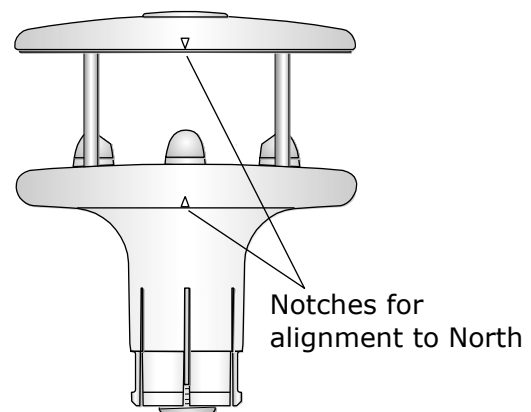

**Housing in aluminum alloy**

If wind speed and direction values are given in polar coordinates,  $0^\circ$  angle corresponds to a wind coming from North.

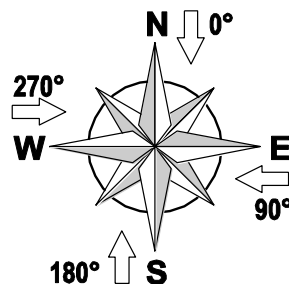

Take into account that the instrument measures the wind direction with respect to the reference on the housing if it is not equipped with compass or the compensation performed by the sensor is disabled.

### 5.2 Electrical Connections

The instrument has 19-pole M23 male connector. Below are the numbering and function of the connector pins and the color correspondence with the wires of the optional **CP51.x** cable.

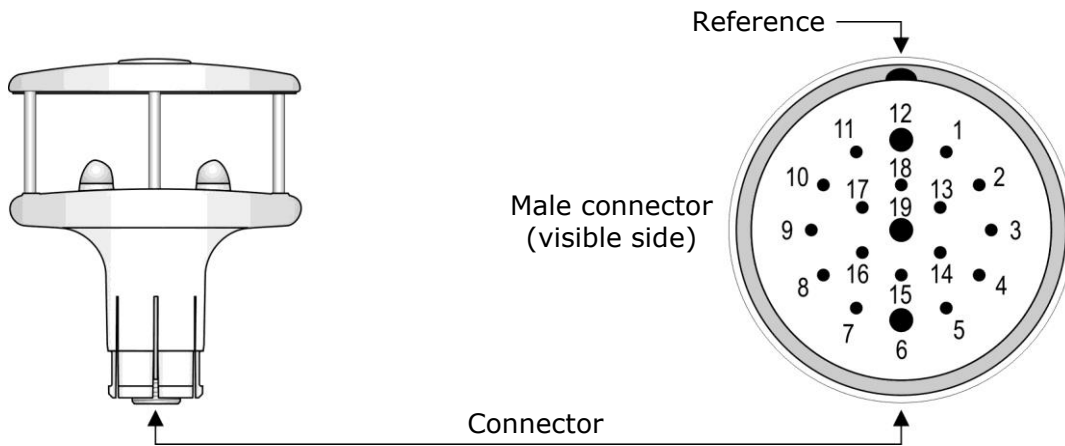

Connector pin number	CP51.x wire color	Symbol	Description
1	White/Pink		Not used
2	White/Grey		Not used
3	Yellow/Brown	RX+	Serial receive (input) positive
4	Brown/Green	HEAT-	Heater power supply negative
5	Violet	HEAT+	Heater power supply positive (24 Vdc)
6	Brown	HEAT-	Heater power supply negative
7	Grey/Brown	HEAT+	Heater power supply positive (24 Vdc)
8	Yellow	DGND	Digital ground (isolated from V-) (*)
9	Grey	TX-	Serial transmission (output) negative "DATA -" main RS485 output
10	White/Yellow	AUX_B	"DATA +" auxiliary RS485 output (D+) (**)
11	White	AUX_A	"DATA -" auxiliary RS485 output (D-) (**)
12	Black	V-	Instrument power supply negative (*)
13	Green	RX-	Serial receive (input) negative
14	Pink/Brown	AOUT1	Analog output 1 positive
15	Blue	AGND	Analog ground (isolated from V-) (*)
16	Red/Blue	AOUT2	Analog output 2 positive
17	White/Green	TX+	Serial transmission (output) positive "DATA +" main RS485 output
18	--		Not used
19	Red	V+	Instrument power supply positive
--	Grey/Red	SHIELD	Cable shield

(\*) DGND and AGND are internally shorted and isolated from V-.

(\*\*) The auxiliary RS485 output is not available in the models measuring T/RH.

**5.2.1 RS232 connection**

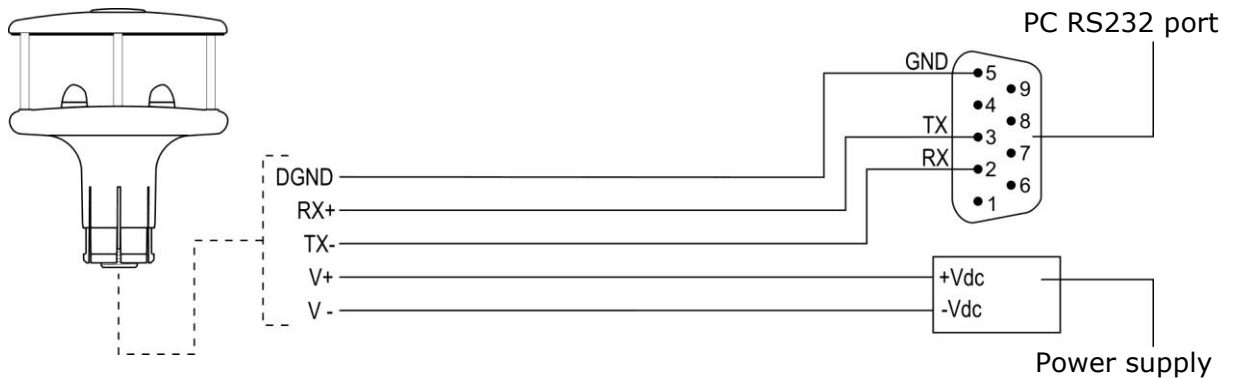

The maximum length of the RS232 connection is typically 15 m.

**5.2.2 RS485 connection**

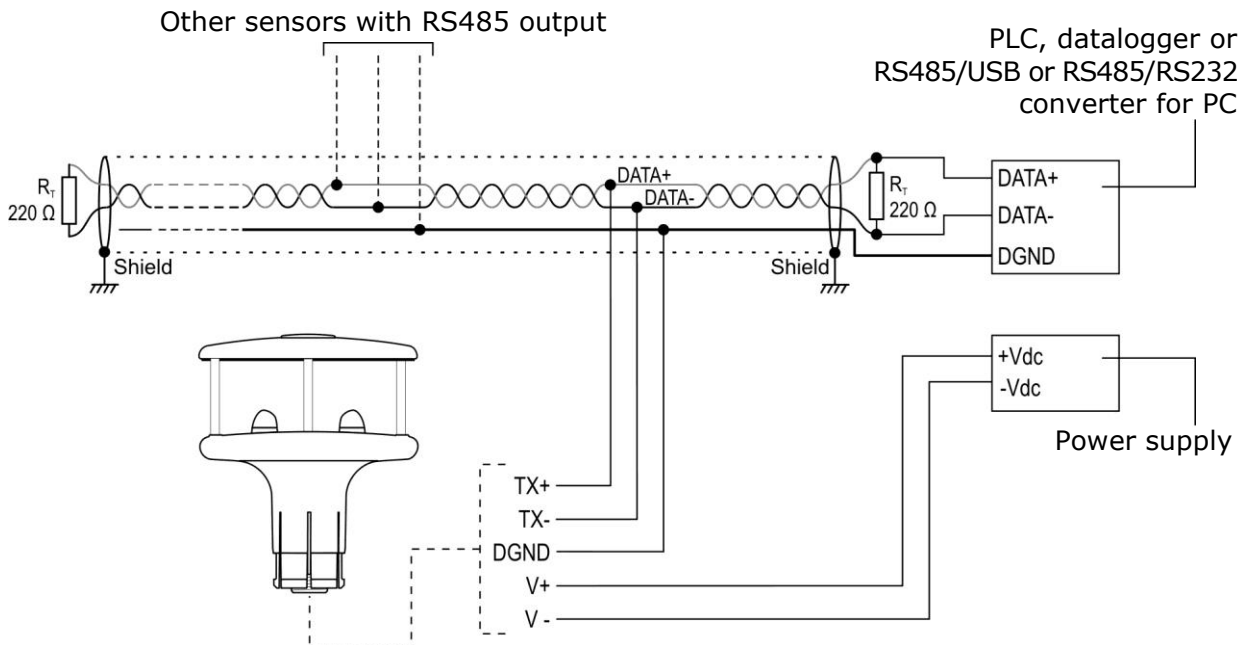

Multiple sensors can be connected in sequence through a twisted-pair shielded cable for signals and a third wire for ground.

The maximum RS485 bus length depends on baud rate and cable characteristics. Typically, using a specific RS485 cable, the maximum length is 1200 m.

Before connecting the anemometer to the network, set the address and the communication parameters, if different from the factory preset (see configuration chapter).

### 5.2.3 RS422 connection

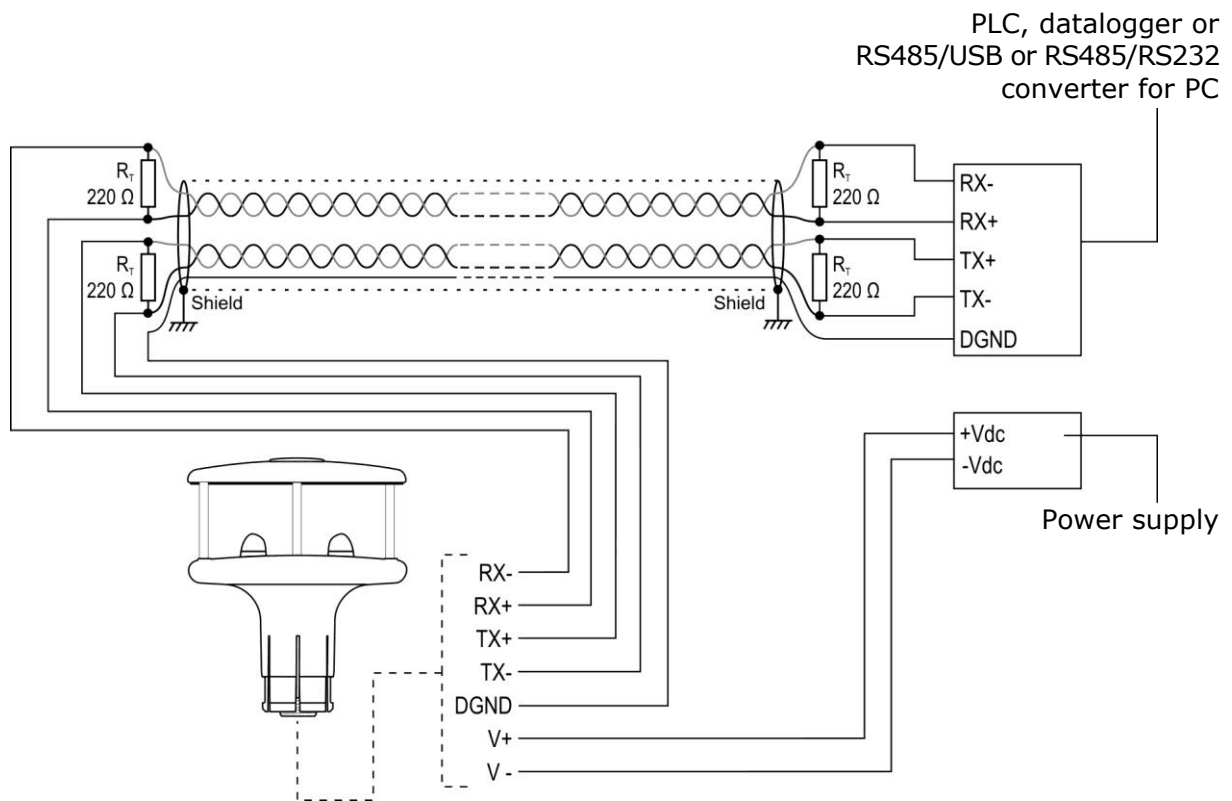

RS422 standard is used for point-to-point connection on long distances, via a shielded cable with two twisted pairs for signals and an additional wire for ground.

The maximum connection length depends on baud rate and cable characteristics. Typically, using a specific RS422 cable, the maximum length is 1200 m.

Before connecting the anemometer to the network, set the address and the communication parameters, if different from the factory preset (see configuration chapter).

### 5.2.4 Analog outputs Connection

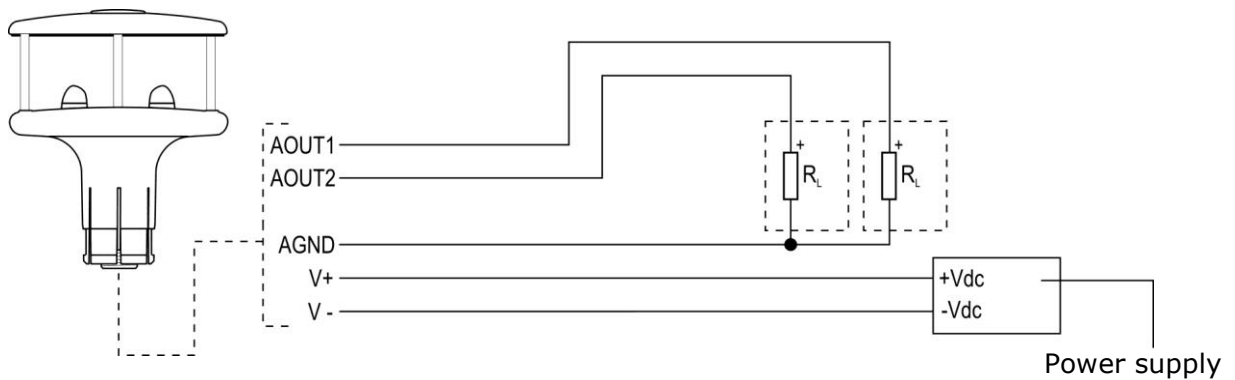

If the CP52.x cable is used, in which AGND is not available, V- can be used as analog ground (AGND and V- are internally shorted).

The anemometer power supply and the load resistance vary according to the type of analog output:

Analog output	Power supply required	Load resistance
0...20 mA	12...30 Vdc	$\leq 500 \Omega$
4...20 mA	12...30 Vdc	$\leq 500 \Omega$
0...1 V	12...30 Vdc	$\geq 10 \text{ k}\Omega$
0...5 V	12...30 Vdc	$\geq 10 \text{ k}\Omega$
0...10 V	15...30 Vdc	$\geq 10 \text{ k}\Omega$

For associating the outputs with the various available parameters, see configuration chapter.

### 5.2.5 Heating connection

The heating power supply (HEAT- e HEAT+) is independent from the instrument main power supply.

Due to the power required by the heating, it is recommended to connect both HEAT- and both HEAT+ wires, so as to halve the current in each wire.

Heating is switched on below +5 °C. After switching on, the heating is switched off when the temperature exceeds +15 °C.



### 5.2.6 Auxiliary RS485 output connection

The auxiliary RS485 output can be used as an alternative to the main serial output (except in the models measuring temperature and relative humidity) for connecting the instrument to the PC, for the configuration of the instrument. The output does not support the operating protocols (NMEA, Modbus-RTU and ASCII proprietary).

For connecting the auxiliary RS485 output to the PC, the optional **RS51K** kit can be used. The kit includes the SWD10 power supply and the RS485/USB adapter with:

- screw terminals for the connection to the CP51... cable (not included);
- USB connector for the connection to the PC;
- jack connector for connecting the SWD10 power supply.

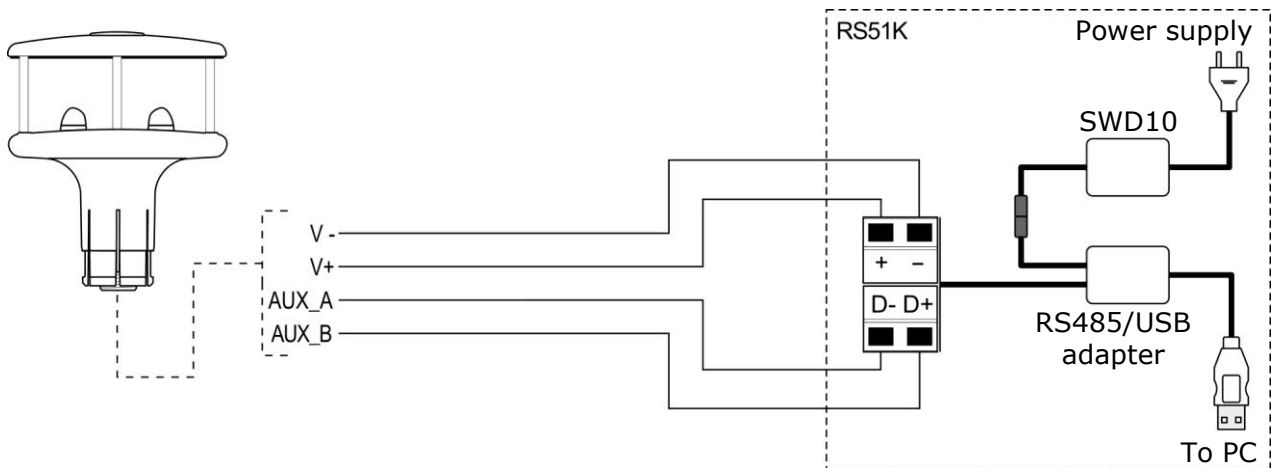

To use the RS51K kit, the USB drivers included in the HD52.3D-S software package should be installed in the PC.

### 5.2.7 RS52 cable connection

The **RS52** optional cable, equipped with RS232/USB converter, allows connecting the instrument RS232 output to a PC USB port.

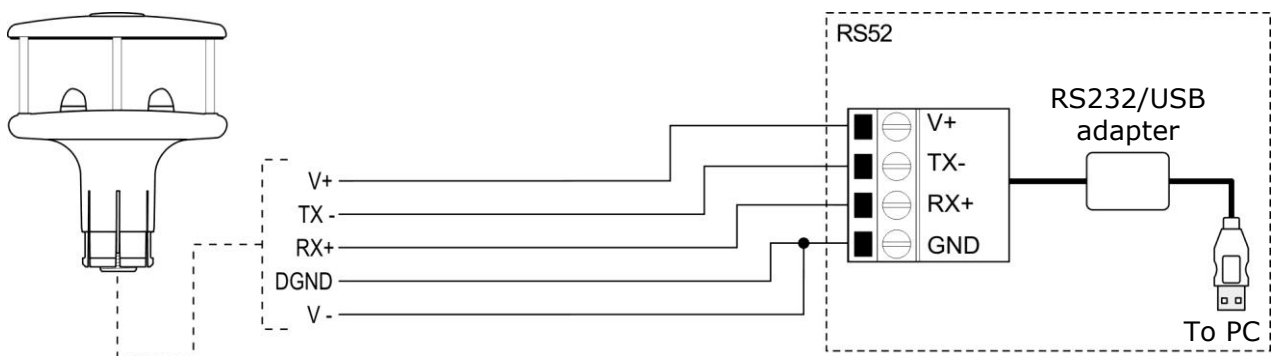

The cable is especially useful for the models measuring temperature and relative humidity, which do not have the auxiliary RS485 serial output.

To use the RS52 cable, the USB drivers included in the HD52.3D-S software package should be installed in the PC.

The instrument is powered directly from the USB port of the PC.

### 5.3 Serial output protocol

Unless otherwise requested, at the first power up the instrument main serial output starts in configuration mode and waits to receive the commands for setting the operating parameters (see configuration chapter) or the connection with the application software.

In this case, in order to activate an operating protocol (NMEA, Modbus-RTU or ASCII proprietary) it is necessary to set it with the appropriate serial command (CUMn, see configuration chapter) or with the aid of the application software.

If the instrument is set up to work with an operating protocol, the protocol becomes active 10 seconds after power on (in the first 10 seconds the instrument waits for a possible command to enter configuration mode, as explained in configuration chapter).

The auxiliary RS485 output is always in configuration mode.

## 6 Configuration

Configuration mode allows reading the instrument general info (firmware version, serial number, ...) and to set the instrument operation mode and operation parameters. The configuration of the instrument can be done in two ways:

- With the aid of **HD52.3D-S** application software (see the software online help), downloadable from Delta OHM website.
- By sending serial commands (listed in paragraph 6.1) via a standard communication program.

If a standard communication program is used, the program communication parameters should be set as follows:

- Baud rate = 115200
- Data bits = 8
- Parity = None
- Stop bits = 2
- Flow control = None

For the configuration, the instrument can be connected to the PC:

- Via **auxiliary RS485** (see paragraph 5.2.6 for the connection), except the models measuring temperature and relative humidity.  
The auxiliary RS485 serial output is always in configuration mode and therefore it is always available to receive commands from the PC.
- Via **RS232** (see paragraphs 5.2.1 and **Errore. L'origine riferimento non è stata trovata.** for the connection).  
The instrument can receive commands from the PC via RS232 only if it is in configuration mode (factory setting, unless otherwise requested).  
If the instrument is not set in in configuration mode but in one of the available operating modes (NMEA, Modbus-RTU or ASCII proprietary), to enter configuration mode it is necessary to send **within 10 seconds from power on** (if the instrument is already powered, disconnect and reconnect the power supply) the serial command @ (if a standard communication program is used) or the request of connection with the HD52.3D-S software, if the application software is used.

### 6.1 Serial Commands

#### Instrument control:

Command	Reply	Description
@	&	Allows entering configuration mode if the instrument is set up in an operating mode. It must be sent within 10 seconds from power on.
#	<i>Info on operating mode</i>	Exits from the configuration mode activated with the command @.

#### Operating Mode:

Command	Reply	Description
CUMn	&	Sets instrument in mode: <ul style="list-style-type: none"> <li>▪ Configuration if n=0</li> <li>▪ RS485 ASCII proprietary if n=1</li> <li>▪ RS232 ASCII proprietary if n=2</li> <li>▪ NMEA if n=4</li> <li>▪ Modbus-RTU if n=5</li> </ul> <i>Default</i> : Configuration (n=0)

Command	Reply	Description
RUM	& n	Reads mode set in the instrument

**Note 1:** after sending the CUMn command, the instrument remains in configuration mode. Power cycle the instrument to activate the set operating mode.

#### Parameters for RS232 and RS485 ASCII proprietary modes:

Command	Reply	Description
CU1Ac	&	Sets the address for RS485 ASCII proprietary mode to c value The address is an alphanumeric character ranging within 0...9, a...z, A...Z <i>Default</i> : 0
RU1A	& c	Reads the address for RS485 ASCII proprietary mode set in the instrument
CU1Bn	&	Sets Baud Rate for RS485 ASCII proprietary mode to: <ul style="list-style-type: none"> <li>▪ 9600 if n=3</li> <li>▪ 19200 if n=4</li> <li>▪ 38400 if n=5</li> <li>▪ 57600 if n=6</li> <li>▪ 115200 if n=7</li> </ul> <i>Default</i> : 115200 (n=7)
RU1B	& n	Reads Baud Rate setting for RS485 ASCII proprietary mode
CU2Bn	&	Sets Baud Rate for RS232 ASCII proprietary mode to: <ul style="list-style-type: none"> <li>▪ 9600 if n=3</li> <li>▪ 19200 if n=4</li> <li>▪ 38400 if n=5</li> <li>▪ 57600 if n=6</li> <li>▪ 115200 if n=7</li> </ul> <i>Default</i> : 115200 (n=7)
RU2B	& n	Reads Baud Rate setting for RS232 ASCII proprietary mode
CU2In	&	Sets interface for ASCII mode to: <ul style="list-style-type: none"> <li>▪ RS232 if n=0</li> <li>▪ RS485 if n=1</li> <li>▪ RS422 if n=2</li> </ul> <i>Default</i> : RS485 (n=1)
RU2I	& n	Reads interface setting for ASCII mode
CU2Mn	&	Sets parity and stop bits for ASCII mode to: <ul style="list-style-type: none"> <li>▪ 8N1 if n=0 [No parity, 1 stop bit]</li> <li>▪ 8N2 if n=1 [No parity, 2 stop bits]</li> <li>▪ 8E1 if n=2 [Even parity, 1 stop bit]</li> <li>▪ 8E2 if n=3 [Even parity, 2 stop bits]</li> <li>▪ 8O1 if n=4 [Odd parity, 1 stop bit]</li> <li>▪ 8O2 if n=5 [Odd parity, 2 stop bits]</li> </ul> The number of data bits is fixed to 8 <i>Default</i> : 8N2 (n=1)

Command	Reply	Description
RU2M	& n	Reads current setting of parity and stop bits for ASCII mode
CU1Dcccccc	&	<p>Sets measurements order in the string sent in ASCII proprietary mode</p> <p>In the sequence ccccccccc, each character identifies a measurement according to the following correspondence:</p> <ul style="list-style-type: none"> <li>0 ⇒ Barometric Pressure</li> <li>1 ⇒ Temperature (sensor Pt100)</li> <li>2 ⇒ Relative Humidity</li> <li>3 ⇒ Pyranometer</li> <li>5 ⇒ Instant speed U,V coordinates</li> <li>7 ⇒ Wind speed average intensity</li> <li>8 ⇒ Wind average direction (Azimuth)</li> <li>G ⇒ Wind Gust (intensity and direction)</li> <li>S ⇒ Sound speed</li> <li>T ⇒ Sonic Temperature</li> <li>C ⇒ Compass, Tilt_Y, Tilt_X</li> <li>E ⇒ Errors</li> </ul> <p><i>Default</i> : 78TE (see <b>Note 2</b>)</p>
RU1D	& ccccccccc	Reads measurements order in the string sent in ASCII proprietary mode
CU2Rnnnn	&	<p>Sets transmission interval of string with measurements in ASCII proprietary mode to nnnn seconds</p> <p>The interval should range within 1 and 3600 seconds</p> <p><i>Default</i> : 1 second</p>
RU2R	& nnnn	Reads transmission interval of string with measurements in ASCII proprietary mode

### **NOTE 2** : MEASUREMENTS ORDER

In the measurement string sent by the instrument in ASCII proprietary mode, measurements can be set in arbitrary order: one should simply indicate the desired order in the sequence of characters "cccccc" sent by the command CU1D. The sequence of characters "cccccc" can have a variable length up to a maximum of 16 characters.

*Example:* if the sequence of characters is set to 780, wind speed, wind direction and barometric pressure measurements will appear from left to right in the data string sent by the instrument.

If information on error conditions is requested (E character), three numbers with the following meaning will appear in the data string sent by the instrument:

1. *First number* = error code identifying the transducers and the type of error.

The number is composed by two digits. The first digit indicates the transducer that presents the error, according to the numeration indicated in the figure shown below.

*Note:* the  $x_{ws}$  and  $y_{ws}$  axes visible in the figure are used internally by the instrument to measure wind speed and direction and have the opposite direction with respect to the X and Y reference axes for the tilt angles described on page 10.

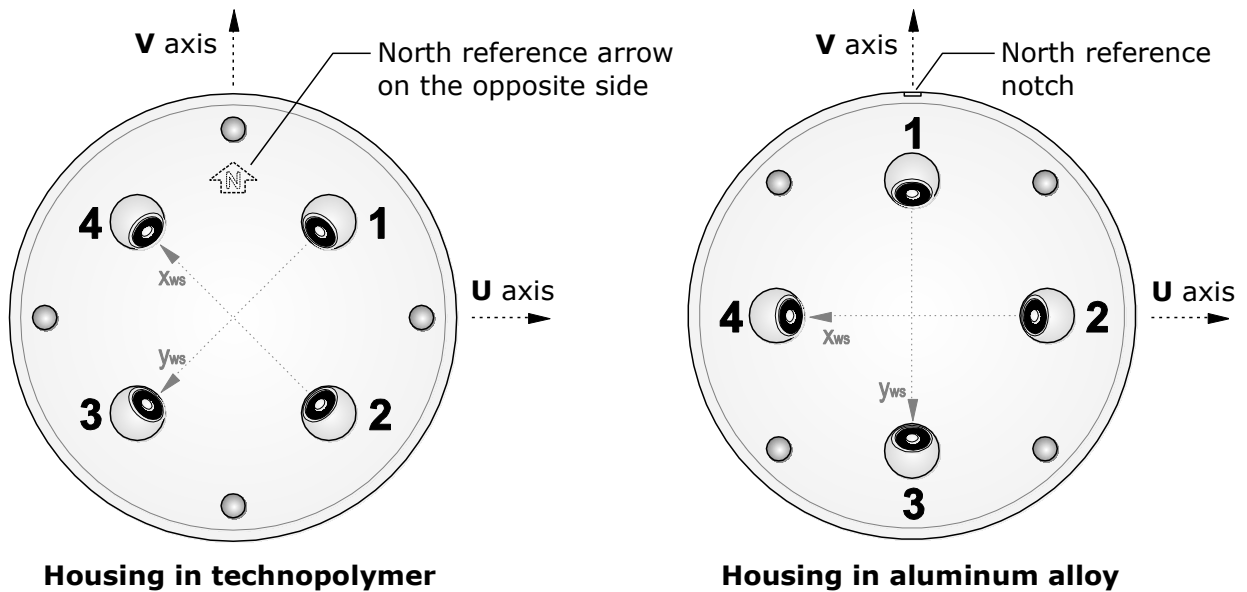

**Housing in technopolymer**

**Housing in aluminum alloy**

Digit 0 indicates that no errors are present in the ultrasonic transducers.

The second digit of the error code indicates the type of error: **0** = no errors; **5** = transducer broken, electric interruption, path obstruction; **Other** = codes reserved to technical service.

2. *Second number* = heating status: **0** = off, **1** = housing heating is on, **2** = housing heating and transducers heating are both on.
3. *Third number* = number of invalid measurements.

*Example:* if **25 0 2** appears in correspondence to the error condition in the data string sent by the instrument, it means that an error occurred in the transducer number 2, that the heating is turned off and that two measurements have been rejected due to the error occurrence.

**Parameters for NMEA mode:**

<b>Command</b>	<b>Reply</b>	<b>Description</b>
CU4Bn	&	Sets Baud Rate for NMEA mode to: <ul style="list-style-type: none"> <li>▪ 2400 if n=1</li> <li>▪ 4800 if n=2</li> <li>▪ 9600 if n=3</li> <li>▪ 19200 if n=4</li> <li>▪ 38400 if n=5</li> <li>▪ 57600 if n=6</li> <li>▪ 115200 if n=7</li> </ul> <i>Default</i> : 4800 (n=2)
RU4B	& n	Reads Baud Rate setting for NMEA mode
CU4In	&	Sets interface for NMEA mode to: <ul style="list-style-type: none"> <li>▪ RS232 if n=0</li> <li>▪ RS485 if n=1</li> <li>▪ RS422 if n=2</li> </ul> <i>Default</i> : RS485 (n=1)
RU4I	& n	Reads interface setting for NMEA mode
CU4Mn	&	Sets parity and stop bits for NMEA mode to: <ul style="list-style-type: none"> <li>▪ 8N1 if n=0 [No parity, 1 stop bit]</li> <li>▪ 8N2 if n=1 [No parity, 2 stop bits]</li> <li>▪ 8E1 if n=2 [Even parity, 1 stop bit]</li> <li>▪ 8E2 if n=3 [Even parity, 2 stop bits]</li> <li>▪ 8O1 if n=4 [Odd parity, 1 stop bit]</li> <li>▪ 8O2 if n=5 [Odd parity, 2 stop bits]</li> </ul> The number of data bits is fixed to 8 <i>Default</i> : 8N1 (n=0)
RU4M	& n	Reads current setting of parity and stop bits for NMEA mode
CU4Rnnn	&	Sets transmission interval of string with measurements in NMEA mode to nnn seconds The interval should range within 1 and 255 seconds <i>Default</i> : 1 second
RU4R	& nnn	Reads setting of transmission interval of string with measurements in NMEA mode

**Parameters for Modbus-RTU mode:**

<b>Command</b>	<b>Reply</b>	<b>Description</b>
CU5Annn	&	Sets Modbus address to nnn The address should range within 1 and 247 <i>Default</i> : 1
RU5A	& nnn	Reads the Modbus address setting
CU5Bn	&	Sets the Baud Rate for Modbus mode to: <ul style="list-style-type: none"> <li>▪ 9600 if n=3</li> <li>▪ 19200 if n=4</li> <li>▪ 38400 if n=5</li> <li>▪ 57600 if n=6</li> <li>▪ 115200 if n=7</li> </ul> <i>Default</i> : 19200 (n=4)
RU5B	& n	Reads Baud Rate setting for MODBUS mode
CU5In	&	Sets interface for Modbus mode to: <ul style="list-style-type: none"> <li>▪ RS232 if n=0</li> <li>▪ RS485 if n=1</li> <li>▪ RS422 if n=2</li> </ul> <i>Default</i> : RS485 (n=1) Note: with RS232 option you can connect to PC or datalogger 1 instrument only; option useful to do tests without RS232/RS485 conversion.
RU5I	& n	Reads interface setting for Modbus mode
CU5Mn	&	Sets parity and stop bits for Modbus mode to: <ul style="list-style-type: none"> <li>▪ 8N1 if n=0 [No parity, 1 stop bit]</li> <li>▪ 8N2 if n=1 [No parity, 2 stop bits]</li> <li>▪ 8E1 if n=2 [Even parity, 1 stop bit]</li> <li>▪ 8E2 if n=3 [Even parity, 2 stop bits]</li> <li>▪ 8O1 if n=4 [Odd parity, 1 stop bit]</li> <li>▪ 8O2 if n=5 [Odd parity, 2 stop bits]</li> </ul> The number of bits is fixed to 8 <i>Default</i> : 8E1 (n=2)
RU5M	& n	Reads the setting of parity and stop bits for Modbus mode
CU5Wn	&	Sets waiting time after transmission in Modbus mode to: <ul style="list-style-type: none"> <li>▪ Immediate reception if n=0 (violates protocol)</li> <li>▪ Waiting 3.5 characters if n=1 (respects protocol)</li> </ul> <i>Default</i> : Waiting 3.5 characters (n=1)
RU5W	& n	Reads current setting of waiting time after transmission in Modbus mode



**Units of measurement:**

Command	Reply	Description
CGUVn	&	Sets measuring unit of wind speed: <ul style="list-style-type: none"> <li>▪ m/s if n=1</li> <li>▪ cm/s if n=2</li> <li>▪ km/h if n=3</li> <li>▪ knot if n=4</li> <li>▪ mph if n=5</li> </ul> <i>Default</i> : m/s (n=1)
RGUV	n	Reads the wind speed measuring unit set in the instrument
CGUTn	&	Sets temperature measuring unit: <ul style="list-style-type: none"> <li>▪ °C if n=1</li> <li>▪ °F if n=2</li> </ul> <i>Default</i> : °C (n=1)
RGUT	n	Reads the temperature measuring unit set in the instrument
CGUPn	&	Sets pressure measuring unit: <ul style="list-style-type: none"> <li>▪ mbar if n=1 [Note:1 mbar=1 hPa]</li> <li>▪ mmHg if n=2</li> <li>▪ inchHg if n=3</li> <li>▪ mmH<sub>2</sub>O if n=4</li> <li>▪ inchH<sub>2</sub>O if n=5</li> <li>▪ atm if n=6</li> </ul> <i>Default</i> : mbar (n=1)
RGUP	n	Reads the pressure measuring unit set in the instrument

**General parameters:**

Command	Reply	Description
CGHn	&	Enables/disables heating: <ul style="list-style-type: none"> <li>- Disables if n=0</li> <li>- Enables if n=1</li> </ul> <i>Default</i> : Enabled (n=1)
RGH	n	Reads heating enabling state set in the instrument
CWCnnnn	&	Sets wind speed threshold to nnnn value (in hundredths of m/s) Value should range within 0 and 100 hundredths of m/s (= 0...1 m/s) <i>Default</i> : 20 (= 0.2 m/s) (see <b>Note 3</b> )
RWC	& nnnn	Reads the wind speed threshold value set in the instrument (in hundredths of m/s)
CWaLnnn	&	Sets time interval for the calculation of average speed and average direction to nnn value Value should range within 1 and 600 s <i>Default</i> : 1 s

Command	Reply	Description
RWaL	& nnn	Reads the time interval for the calculation of average speed and average direction set in the instrument
CWaMn	&	Sets the method for the calculation of average speed and average direction: <ul style="list-style-type: none"> <li>▪ If n=0: scalar average.</li> <li>▪ If n=1: vector average.</li> </ul> <i>Default</i> : vector average (n=1) (see <b>Note 4</b> )
RWaM	& n	Reads the method for the calculation of the average speed and average direction set in the instrument
CWgLnnn	&	Sets time interval for the calculation of averages in Wind Gust measurement to nnn value Value should range within 1 and 100 s <i>Default</i> : 3 s (standard WMO value) (see <b>Note 6</b> )
RWgL	& nnn	Reads the time interval for the calculation of averages in Wind Gust measurement set in the instrument
CWgMn	&	Sets the method for the calculation of averages in Wind Gust measurement: <ul style="list-style-type: none"> <li>▪ scalar average if n=0</li> <li>▪ vector average if n=1</li> </ul> <i>Default</i> : vector average (n=1) <i>Note: see the description of the command CWaMn for the meaning of scalar average and vector average.</i>
RWgM	& n	Reads the method for the calculation of averages in Wind Gust measurement set in the instrument
CWgOnnn	&	Sets time interval for detecting the maximum of the averages in Wind Gust measurement to nnn value Value should range within 1 and 600 s <i>Default</i> : 60 s (see <b>Note 6</b> )
RWgO	& nnn	Reads the time interval for detecting the maximum of the averages in Wind Gust measurement set in the instrument
CCn	&	Enables/disables the compensation of wind speed and direction with compass and tilt angles measurements: <ul style="list-style-type: none"> <li>▪ Disables if n=N</li> <li>▪ Enables if n=Y</li> </ul> <i>Default</i> : Enabled (n=Y)
RCU	& n	Reads the enabling status of the compensation of wind speed and direction with compass and tilt angles measurements

Command	Reply	Description
cxd nn.n	cxd	Sets the magnetic declination to nn.n° Value should range within -90.0 and +90.0 <i>Default</i> : see <b>Note 7</b>
rxd	Direction offset to N mark nn.n°	Reads the magnetic declination set in the instrument
cor n	cor	Sets the measurement rate to n Hz (measurements per second) Value should range within 1 and 4 <i>Default</i> : 4
ror	n samples per second	Reads the measurement rate set in the instrument

**NOTE 3 : WIND SPEED THRESHOLD VALUE**

If the wind speed is very low, the determination of the direction can result inaccurate. The instrument allows setting the threshold value of speed below which the direction value is frozen on the last acquired value.

**NOTE 4 : SCALAR AVERAGE AND VECTOR AVERAGE**

**Scalar average:** the average intensity is calculated as average of intensities. For the calculation of the average direction, also called "prevailing direction", the velocity **versor** (unit vector having the same direction of the velocity vector) is considered for each measurement, and the versor coordinates along the measurement axes are calculated, then the average of the coordinates along each axis is calculated. The two average coordinates determine the average versor and therefore the average direction. The average direction is expressed according to the extended characteristic for the analog output (see **Note 5**).

**Vector average:** for each measurement, the coordinates of the velocity vector along the measurement axes are calculated and then the average of the coordinates along each axis is calculated. The average intensity and the average direction are those determined by the two average coordinates.

**NOTE 5 : WIND DIRECTION EXTENDED CHARACTERISTIC**

With 0÷359.9° wind direction measuring range, the analog output continues to oscillate between maximum and minimum scale if the direction continues to slightly fluctuate around 0°:

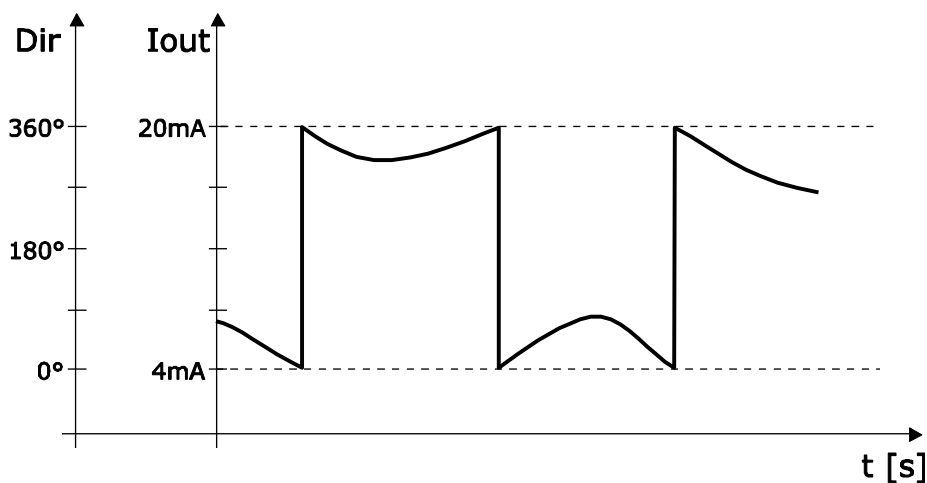

This effect can be reduced through the extended ("wrap-around") characteristic of wind direction. In this mode, the wind direction is considered as corresponding to 0÷539.9° range instead of 0÷359.9°. The wide output fluctuation occurs the first time that the wind direction goes from 0 to 359.9°; if later the "physical" direction goes back to 0°, the analog output will always remain around 360°. Using the extended characteristic, the behavior of the above

graph changes into the following:

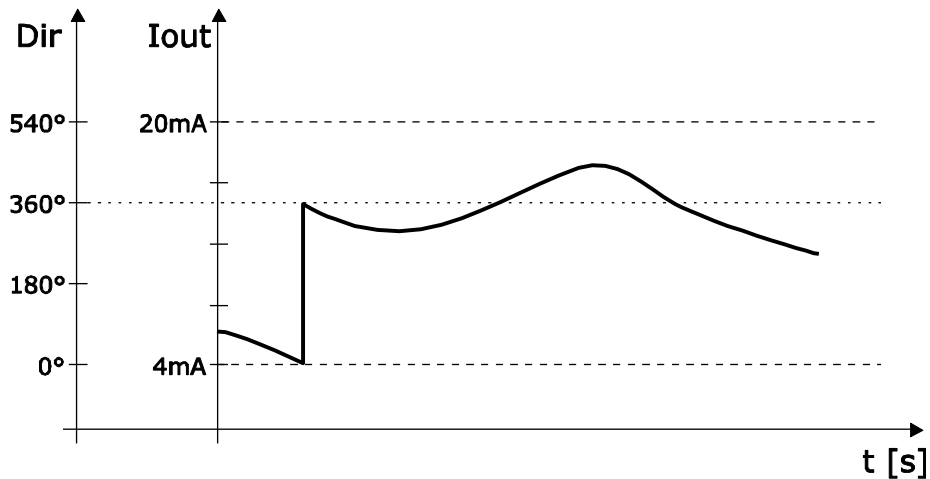

If 539.9° value is exceeded in extended mode, the output goes to the value corresponding to 180°.

The table below shows the correspondence between the value of the analog output and the direction of the wind in the two modes.

Wind direction	4...20mA output		0...1V output		0...5V output		0...10V output	
	standard	extended	standard	extended	standard	extended	standard	extended
0°	4.00	4.00	0.00	0.00	0.00	0.00	0.00	0.00
180°	12.00	9.33	0.50	0.33	2.50	1.67	5.00	3.33
360°	20.00	14.67	1.00	0.67	5.00	3.33	10.00	6.67
540°	--	20.00	--	1.00	--	5.00	--	10.00

#### **NOTE 6** : WIND GUST MEASUREMENT

The Wind Gust measurement is determined as follows:

- the wind speed averages (according to the method set with the **CWgM** command, by default vector averages) in a time interval equal to that set with the **CWgL** command (by default 3 seconds) are calculated continuously;
- the maximum value of the averages calculated in the previous point is detected over a time interval equal to that set with the **CWgO** command (by default 60 seconds); the maximum value detected is the measure of Wind Gust.

#### **NOTE 7** : MAGNETIC DECLINATION

The set value is used to compensate the measurement and refer it to the geographical North if the compensation of wind speed and direction with compass measurement is enabled (command CCn). The default value is 0 for the models equipped with compass.

If the compass is disabled, for a correct measurement with respect to the notch/arrow referring to the North the parameter must be set to 0 in the models with anodized aluminum alloy housing and 45 in the models with technopolymer housing.

In the models not equipped with compass, the parameter is set by default to 0 in the models with anodized aluminum alloy housing and to 45 in the models with technopolymer housing. In these models the parameter should not be changed.

**Analog outputs:**

Command	Reply	Description
RAT	& n	Reads the analog output type: <ul style="list-style-type: none"> <li>▪ 4...20/0...20 mA if n=0</li> <li>▪ 0...1 V if n=1</li> <li>▪ 0...5 V if n=2</li> <li>▪ 0...10 V if n=3</li> </ul>
CAFxnn	&	Sets offset and direction of the analog output x (x=1 or 2) to: <ul style="list-style-type: none"> <li>▪ Standard if nn=00 [ex. 4...20 mA, 0...1 V, 0...5 V, 0...10 V]</li> <li>▪ Without offset if nn=01 [ex. 0...20 mA]</li> <li>▪ With offset if nn=02 [ex. 0.2...1 V, 1...5 V, 2...10 V]</li> <li>▪ Inverted if nn=04 [ex. 20...4 mA, 1...0 V, 5...0 V, 10...0 V]</li> <li>▪ Inverted without offset if nn=05 [ex. 20...0 mA]</li> <li>▪ Inverted with offset if nn=06 [ex. 1...0.2 V, 5...1 V, 10...2 V]</li> </ul> <p><i>Default</i> : Standard (nn=00)</p>
RAFx	& nn	Reads offset and direction setting of the analog output x (x=1 or 2)
CAMn	&	Association of the analog outputs: <ul style="list-style-type: none"> <li>▪ If n= 0: Output 1 = Mean wind speed Output 2 = Mean wind direction (with extended characteristic if the average is scalar)</li> <li>▪ If n= 1 (see <b>Note 8</b>): Output 1 = Instant wind speed component along V-axis Output 2 = Instant wind speed component along U-axis</li> <li>▪ If n= 2 (<b>Tunnel</b> mode, see <b>Note 9</b>): Output 1 = Instant wind speed component along the direction indicated by the reference (arrow or notch) on the instrument housing Output 2 = Instant wind direction referred to the direction indicated by the reference (arrow or notch) on the instrument housing</li> </ul> <p><i>Default</i> : n=0</p>
RAM	& n	Reads the association of analog outputs

Command	Reply	Description
CAHn	&	Associates full scale of wind speed analog output to: <ul style="list-style-type: none"> <li>▪ 5 m/s if n=0</li> <li>▪ 10 m/s if n=1</li> <li>▪ 15 m/s if n=2</li> <li>▪ 20 m/s if n=3</li> <li>▪ 25 m/s if n=4</li> <li>▪ 30 m/s if n=5</li> <li>▪ 35 m/s if n=6</li> <li>▪ 40 m/s if n=7</li> <li>▪ 45 m/s if n=8</li> <li>▪ 50 m/s if n=9</li> <li>▪ 55 m/s if n=10</li> <li>▪ 60 m/s if n=11</li> <li>▪ 65 m/s if n=12</li> <li>▪ 70 m/s if n=13</li> <li>▪ 75 m/s if n=14</li> <li>▪ 80 m/s if n=15</li> <li>▪ 85 m/s if n=16</li> <li>▪ 90 m/s if n=17</li> </ul> Default : 75 m/s (n=14)
RAH	& n	Reads the value corresponding to the wind speed analog output full scale

**NOTA 8** : U,V COMPONENTS

By selecting the U and V components, the speed value associated to the initial scale of the two analog outputs is equal to the opposite of the speed value associated to the full scale of the outputs.

For example, if the speed full scale value is set to 60 m/s, the speed range associated to the analog outputs is -60...+60 m/s.

**NOTA 9** : TUNNEL MODE

The reference (arrow or notch) on the instrument housing should be aligned with the direction of the tunnel.

The output 2 is set to full scale value if the wind blows in the direction pointed by the reference, and to initial scale value if the wind blows in the opposite direction.

The initial scale of output 1 is associated to the speed value opposite to that associated to the output full scale.

**Instrument information:**

Command	Reply	Description
G1	&VPnn.nn yyyy/mm/dd	Version and date of firmware
RGS	&nnnnnnnn	Serial number of instrument
RGI	&ccc...ccc	User code
CGIccc...ccc	&	Sets user code to ccc...ccc (max. 34 characters)

## 7 RS232 ASCII proprietary mode

In RS232 ASCII proprietary mode, the instrument sends automatically the acquired measurements at regular intervals. The interval is factory-set to 1 second and is configurable from 1 to 3600 seconds. To change the interval, you should enter in configuration mode and send the command **CU2Rnnnn**, where nnnn indicates the interval value in seconds (see chapter 6 for details regarding the setting of operation parameters).

Communication parameters should be set in your PC as follows:

- Baud rate: same as the setting in the instrument (default = 115200)
- Data bits: 8
- Parity: same as the setting in the instrument (default = None)
- Stop bits: same as the setting in the instrument (default = 2)

The instrument sends measurements in the following format:

**<M1><M2>...<Mn><CR><LF>**

with <M1><M2>...<Mn> = values of the first, second, ..., nth measurement

<CR> = ASCII character *Carriage Return*

<LF> = ASCII character *Line Feed*

Fields <M1><M2>...<Mn> consist of 8 characters each. Measurement values are justified right; spaces can be added to the left margin of the values to obtain the 8 character length requested by the fields.

The sequence of the measurement values <M1><M2>...<Mn> is configurable (command **CU1Dcccccc**, see chapter 6).

### EXAMPLE

Supposing that the instrument measures the following values (the measuring unit is not considered, being not output by the instrument): M1=28.30, M2=359.3, M3=998.3, the data string sent by the instrument takes the form:

28.30 359.3 998.3<CR><LF>

## 8 RS485 ASCII proprietary mode

In RS485 ASCII proprietary mode, the instrument sends the acquired measurements only if requested by the PC.

To use this mode, you must connect to a RS485 or RS422 serial port. Communication parameters should be set in the PC or data logger as follows:

- Baud rate: same as the setting in the instrument (default = 115200)
- Data bits: 8
- Parity: same as the setting in the instrument (default = None)
- Stop bits: same as the setting in the instrument (default = 2)

The instrument is requested to send measurements by generating a *Break Signal* (\*) on the serial line for at least 2 ms, and then sending the following command, consisting of 4 ASCII characters:

**M<Address><x>G**

with <Address> = address of the instrument measurements are requested to  
<x> = any ASCII character, except G

### EXAMPLE

To ask the instrument with address 2 to send the acquired measurements, do the following:

- 1) **Break Signal** for at least 2 ms;
- 2) Send command: **M2aG**.

The instrument answers with the following string:

**IIIIIM<Address>I&<M1><M2>...<Mn><SP>&AAAM<Address><CS><CR>**

with <Address> = address of the instrument sending measurements  
<M1><M2>...<Mn> = values of the first, second, ..., nth measurement  
<SP> = space  
<CS> = checksum (hex value of the 8-bit checksum of all the preceding characters)  
<CR> = ASCII character Carriage Return

Fields <M1><M2>...<Mn> consist of 8 characters each. Measurement values are justified right; spaces can be added to the left margin of the values to obtain the 8 character length requested by the fields. The sequence of the measurement values <M1><M2>...<Mn> is configurable (command **CU1Dcccccc**, see chapter 6).

### EXAMPLE

Supposing that the instrument with address 2 measures the following values (the measuring unit is not considered, being not output by the instrument): M1=2.23, M2=-28.34, M3=0.34, M4=28.30, M5=359.3, M6=-1.3, the instrument reply takes the following form:

IIIIIM2I& 2.23 -28.34 0.34 28.30 359.3 -1.3 &AAAM28C<CR>

A minimum time interval should elapse between two commands, depending on the Baud Rate setting:

Baud Rate	Minimum interval between two commands
9600	200 ms
19200	100 ms
38400	70 ms
57600	40 ms
115200	25 ms

(\*) **Break Signal** means interruption of the serial communication for a given time interval. It is used to inform the devices connected to the network that a command is going to be sent.



## 9 NMEA mode

NMEA protocol, mainly used in the nautical field and in satellite-based navigation systems, specifies that only one of the devices connected can send data, while the others can only act as recipients.

In NMEA mode, the instrument sends automatically the acquired measurements at regular intervals. The interval is factory-set to 1 second and can be configured within 1 and 255 seconds. To change the interval you should access the configuration mode and send **CU4Rnnn** command, where nnn indicates the interval value in seconds (see chapter 6 for details regarding the setting of operation parameters).

Communication parameters should be set in the PC or data logger as follows:

- Baud rate: same as the setting in the instrument (default = 4800)
- Data bits: 8
- Parity: same as the setting in the instrument (default = None)
- Stop bits: same as the setting in the instrument (default = 1)

The instrument is compatible with NMEA 0183 V4.00 protocol.

The protocol establishes that data are sent in the following format:

**\$<Prefix>,<Data>\*<hh><CR><LF>**

- with <Prefix> = field consisting in 5 alphanumeric characters: the first two indicate the type of transmitting device, the other three indicate the type of transmitted data
- <Data> = values measured by the instrument, separated by commas
- <hh> = checksum, consisting in two hexadecimal characters
- <CR> = character ASCII Carriage Return
- <LF> = character ASCII Line Feed

The checksum is calculated by performing the exclusive OR of all characters ranging within \$ and \* symbols. The 4 most significant bits and the 4 less significant bits of the result are converted in hexadecimal. The hexadecimal value corresponding to the most significant bits is transmitted as the first.

The instrument regularly sends a string in the following general format requested by the protocol:

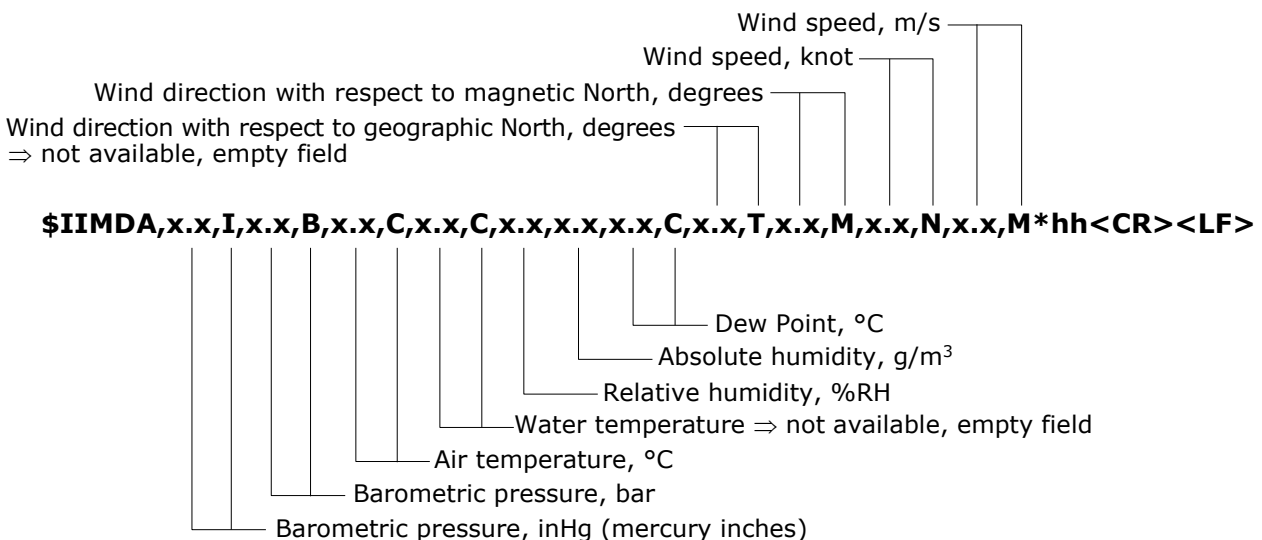

The fields related to quantities not measured by the instrument are empty (multiple consecutive commas appear to indicate the missing fields).

The previous string is followed by a second string (\$IIXDR...) including the solar radiation and tilt angles measurements:

**\$IIXDR,G,x.x,,PYRA,G,x.x,,TILTX,G,x.x,,TILTY\*hh<CR><LF>**

#### EXAMPLE

Suppose that there are the following environmental conditions:

- Wind speed = 5.60 m/s (=10.88 knot)
- Wind direction with respect to magnetic North = 38.7°
- Barometric pressure = 1014.9 hPa (= 30.0 inHg)
- Relative humidity = 64.2 %
- Air temperature = 26.8 °C
- Solar radiation = 846 W/m<sup>2</sup>

Based on the above values, the following can be calculated:

- Absolute humidity = 16.4 g/m<sup>3</sup>
- Dew Point = 19.5 °C

The strings sent by the instrument in three different cases are indicated below:

- Case 1 – instrument measuring only wind speed and direction:

```
$IIMDA,,I,,B,,C,,C,,,,C,,T,38.7,M,10.88,N,5.60,M*3A<CR><LF>
```

- Case 2 - instrument measuring wind speed and direction, temperature, relative humidity and barometric pressure:

```
$IIMDA,30.0,I,1.0149,B,26.8,C,,C,64.2,16.4,19.5,C,,T,38.7,M,10.88,N,5.60,M*36<CR><LF>
```

- Case 3 - instrument measuring wind speed and direction, solar radiation, temperature, relative humidity, barometric pressure and tilt angles:

```
$IIMDA,30.0,I,1.0149,B,26.8,C,,C,64.2,16.4,19.5,C,,T,38.7,M,10.88,N,5.60,M*36<CR><LF>
```

alternated to:

```
$IIXDR,G,846,,PYRA,G,1.15,,TILTX,G,0.80,,TILTY*25<CR><LF>
```

For additional information regarding the protocol, visit the site "[www.nmea.org](http://www.nmea.org)".

## 10 Modbus-RTU mode

In Modbus-RTU mode, the instrument sends the acquired measurements only if specifically requested by the PC, PLC or data logger.

Communication parameters should be set in the PC or data logger as follows:

- Baud rate: same as the setting in the instrument (default = 19200)
- Data bits: 8
- Parity: same as the setting in the instrument (default = even)
- Stop bits: same as the setting in the instrument (default = 1)

Below is the list of registers.

### Input Registers

Address	Description	Format
0	Instantaneous wind speed (x100)	unsigned 16 bits
1	Instantaneous wind direction in degrees (x10)	unsigned 16 bits
2	Sonic temperature measured by the transducers pair 2-4 (x10). See page 22 for the transducers numbering.	16 bits
3	Sonic temperature measured by the transducers pair 1-3 (x10). See page 22 for the transducers numbering.	16 bits
4	Average of the two sonic temperatures measured by the two transducers pairs (x10)	16 bits
5	Temperature measured by Pt100 sensor (x10)	16 bits
6	Relative humidity in %RH (x10)	unsigned 16 bits
7	Barometric pressure (x1000 if the unit of measurement is atm, x10 in the other cases)	unsigned 16 bits
8	Compass angle in degrees (x10)	unsigned 16 bits
9	Solar radiation in W/m <sup>2</sup>	unsigned 16 bits
10	Average wind speed (x100)	unsigned 16 bits
11	Average wind direction (Azimuth) in degrees (x10)	unsigned 16 bits
12	Absolute humidity in g/m <sup>3</sup> (x100)	unsigned 16 bits
13	Dew point temperature (x10)	16 bits
14	Instantaneous wind direction (Azimuth) in degrees (x10) with extended feature (see page 27)	unsigned 16 bits
15	Instantaneous wind speed (x100) along V-axis	unsigned 16 bits
16	Instantaneous wind speed (x100) along U-axis	unsigned 16 bits
17	Status register bit0=1 ⇒ speed measurement error bit1=1 ⇒ compass and tilt angles measurement error bit2=1 ⇒ temperature meas. error bit3=1 ⇒ humidity measurement error bit4=1 ⇒ pressure measurement error bit5=1 ⇒ solar radiation measurement error	unsigned 16 bits
18	Wind speed unit of measurement 0 ⇒ m/s            3 ⇒ knot 1 ⇒ cm/s         4 ⇒ mph 2 ⇒ km/h	unsigned 16 bits

Address	Description	Format
19	Temperature unit of measurement 0 ⇒ °C            1 ⇒ °F	unsigned 16 bits
20	Barometric pressure unit of measurement 0 ⇒ mbar (=hPa)    3 ⇒ mmH <sub>2</sub> O 1 ⇒ mmHg            4 ⇒ inchH <sub>2</sub> O 2 ⇒ inchHg           5 ⇒ atm	unsigned 16 bits
21	Wind Gust intensity (x100)	unsigned 16 bits
22	Wind Gust direction (Azimuth) in degrees (x10)	unsigned 16 bits
24	Tilt_Y in degrees (x10)	16 bits
25	Tilt_X in degrees (x10)	16 bits

*Note:* for quantities with configurable measurement unit, the measurement value is expressed in the unit set in the instrument.

For additional information regarding the protocol, visit the site "[www.modbus.org](http://www.modbus.org)".

## 11 Maintenance

Wind speed sensors does not generally require maintenance.

In case abnormal measures are detected, verify the cleanliness of the ultrasonic sensors. For cleaning, use a moistened soft cloth. The sensors should be wiped gently: **do not brush or twist the sensors.**

## 12 Instrument storage

Instrument storage conditions:

- Temperature: -40...+70 °C.
- Humidity: less than 90 %RH no condensation.
- In storing, avoid locations where:
  - There is a high humidity level.
  - The instrument is exposed to direct sunlight.
  - The instrument is exposed to a high temperature source.
  - There are high vibration levels.
  - There is presence of vapor, salt and/or corrosive gas.

## 13 Safety instructions

The instrument proper operation and operating safety can be ensured only in the climatic conditions specified in this manual and if all standard safety measures as well as the specific measures described in this manual are followed.

Do not use the instrument in places where there are:

- Corrosive or flammable gases.
- Direct vibrations or shocks to the instrument.
- High-intensity electromagnetic fields, static electricity.

### User obligations

The instrument operator shall follow the directives and regulations below that refer to the treatment of dangerous materials:

- EU directives on workplace safety.
- National law regulations on workplace safety.
- Accident prevention regulations.

## 14 Accessories ordering codes

- CP51...** Connecting cable with 19-pole M23 female free connector on one end, open wires on the other. Available lengths: 5 m (CP51.5) and 10 m (CP51.10).
- RS51K** Kit for connecting the anemometer RS485 output to a PC. It includes the SWD10 power supply and the RS485/USB adapter with:
- screw terminals for the connection to the CP51... cable (not included);
  - USB connector for the connection to the PC;
  - jack connector for connecting the SWD10 power supply.
- RS52** Serial connection cable with built-in RS232/USB converter. USB connector for the PC and screw terminals on the instrument side.
- CP52.C** Additional 19-pole M23 female free connector.

## **WARRANTY**

The manufacturer is required to respond to the "factory warranty" only in those cases provided by Legislative Decree 6 September 2005 - n. 206. Each instrument is sold after rigorous inspections; if any manufacturing defect is found, it is necessary to contact the distributor where the instrument was purchased from. During the warranty period (24 months from the date of invoice) any manufacturing defects found will be repaired free of charge. Misuse, wear, neglect, lack or inefficient maintenance as well as theft and damage during transport are excluded. Warranty does not apply if changes, tampering or unauthorized repairs are made on the product. Solutions, probes, electrodes and microphones are not guaranteed as the improper use, even for a few minutes, may cause irreparable damages.

The manufacturer repairs the products that show defects of construction in accordance with the terms and conditions of warranty included in the manual of the product. For any dispute, the competent court is the Court of Padua. The Italian law and the "Convention on Contracts for the International Sales of Goods" apply.

## **TECHNICAL INFORMATION**

The quality level of our instruments is the result of the continuous product development. This may lead to differences between the information reported in the manual and the instrument you have purchased.

We reserve the right to change technical specifications and dimensions to fit the product requirements without prior notice.

## **DISPOSAL INFORMATION**

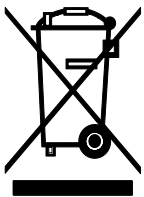

Electrical and electronic equipment marked with specific symbol in compliance with 2012/19/EU Directive must be disposed of separately from household waste. European users can hand them over to the dealer or to the manufacturer when purchasing a new electrical and electronic equipment, or to a WEEE collection point designated by local authorities. Illegal disposal is punished by law.

Disposing of electrical and electronic equipment separately from normal waste helps to preserve natural resources and allows materials to be recycled in an environmentally friendly way without risks to human health.



[senseca.com](http://senseca.com)



Senseca Italy S.r.l.  
Via Marconi, 5  
35030 Selvazzano Dentro (PD)  
ITALY  
[info@senseca.com](mailto:info@senseca.com)

