

Operating manual

Low pressure
transmitter / data logger

HD50CR-AS



Members of GHM GROUP:

GREISINGER

HONSBERG

Martens

Delta OHM

VAL.CO

www.deltaohm.com

Keep for future reference.

TABLE OF CONTENTS

1	INTRODUCTION	3
2	DESCRIPTION	4
3	INSTALLATION	5
	3.1 CONFIGURATION	6
4	ALARMS	8
5	STATISTICAL FUNCTIONS.....	10
6	CALIBRATION	11
7	MENU	12
8	MODBUS	17
9	TECHNICAL CHARACTERISTICS	23
10	INSTRUMENT STORAGE	26
11	SAFETY INSTRUCTIONS	26
12	PROBES AND ACCESSORIES ORDERING CODES	27

1 INTRODUCTION

HD50CR-AS is a relative or differential low pressure transmitter and data logger designed for wall flush-mounting. Measuring range ± 100 Pa.

A silicon piezoresistive sensor with high accuracy and temperature compensation is used, which allows excellent linearity, repeatability and stability over the time. The auto-zeroing feature allows stable measurements over the time without the need to recalibrate.

An input for an optional relative humidity and temperature combined probe is provided. The absolute humidity, the Dew Point and the wet bulb temperature can be calculated.

Three 0...5/10 V and 0/4...20 mA analog outputs and a digital RS485 output with **"Slave" Modbus-RTU** protocol for connecting the instrument to a network of sensors are available.

The electroluminescent display has an inattinic red protection. The front keyboard allows scrolling the real time measurements and configuring the instrument.

Equipped with a USB port with mini-USB connector for the connection to a PC.

For each detected quantity, two alarm thresholds can be set by the user. Exceeding a threshold is signaled acoustically, by means of the internal buzzer, and visually, by lighting the alarm LEDs on the front panel (only for the three measurements associated with the analog outputs). An alarm hysteresis and a delay in the generation of the alarm can be configured for each detected quantity.

The PC software **HD35AP-S** allows configuring the instrument, viewing the real time measurements, downloading and viewing the data into a database. The **HD35AP-CFR21** software option allows the protection of recorded data and configuration in response to **FDA 21 CFR part 11** recommendations.

Brushed stainless steel front panel.

The instrument is supplied factory calibrated.

2 DESCRIPTION

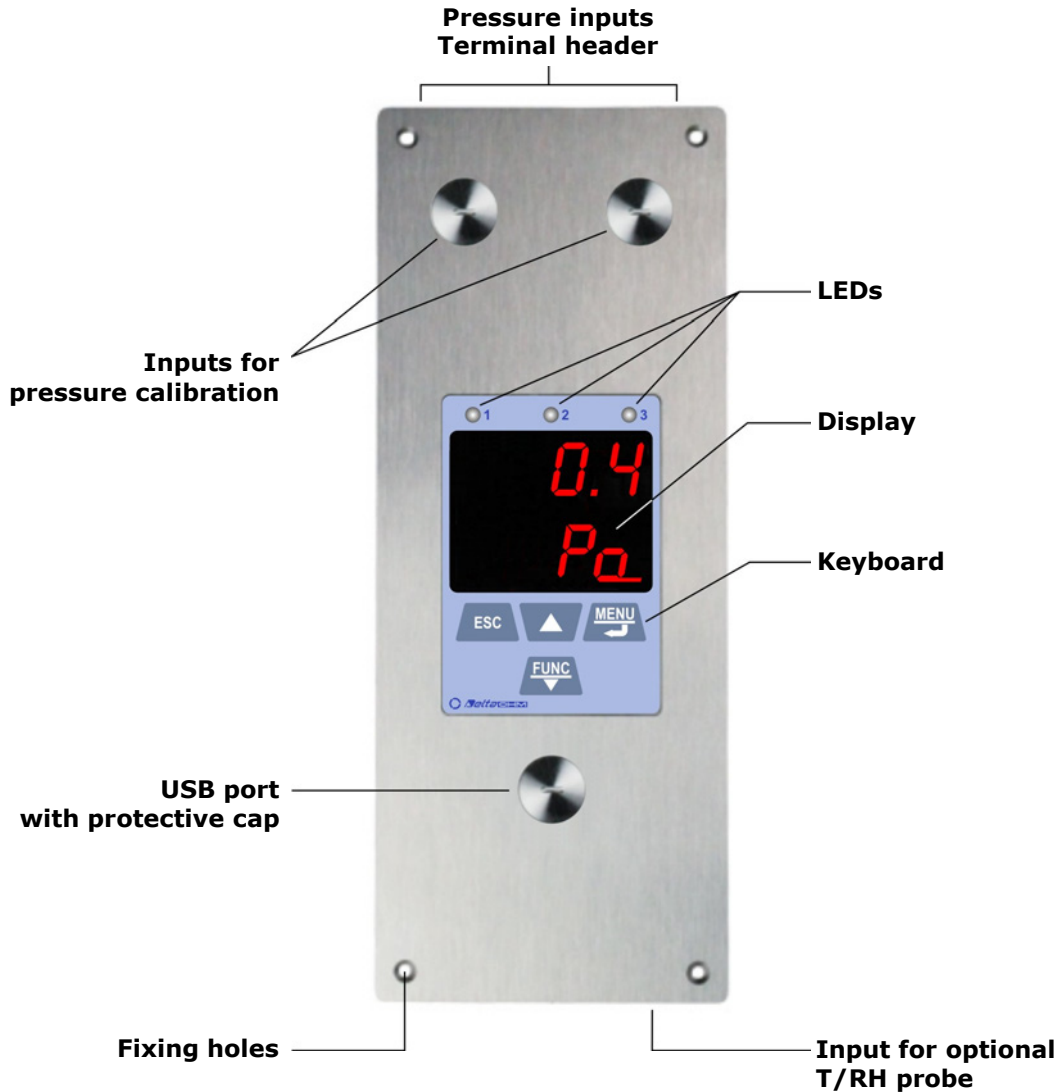

Buttons:



Scrolls the real time measurement on the display.
In menu, increases the displayed value or move to the next parameter.



Displays the statistical functions (MIN, MAX, AVG).
In menu, decreases the displayed value or move to the previous parameter.



Enters the menu.
In menu, confirms the displayed value.



Cancel the operation or goes back to the previous level.

3 INSTALLATION

Make a 196 x 70 mm cut in the wall, at least 46 mm deep, and 4 holes according to the drilling pattern shown below, then wall mount the instrument by using the 4 holes on the front panel.

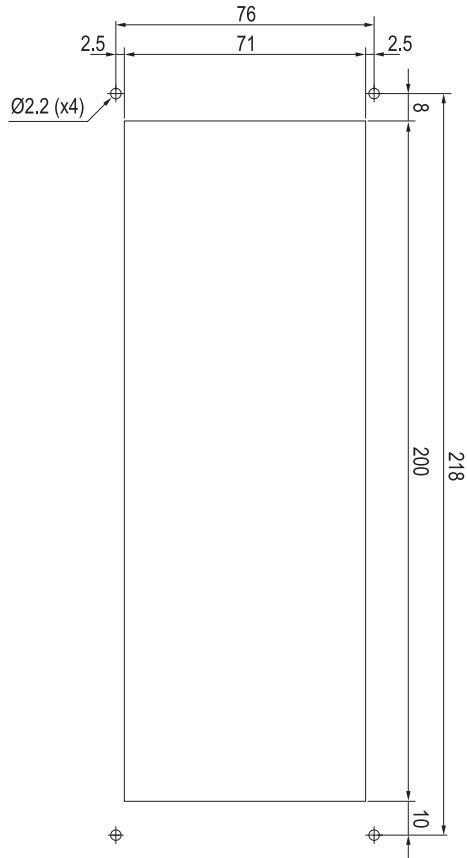

The connections on the upper part of the housing are as follows:

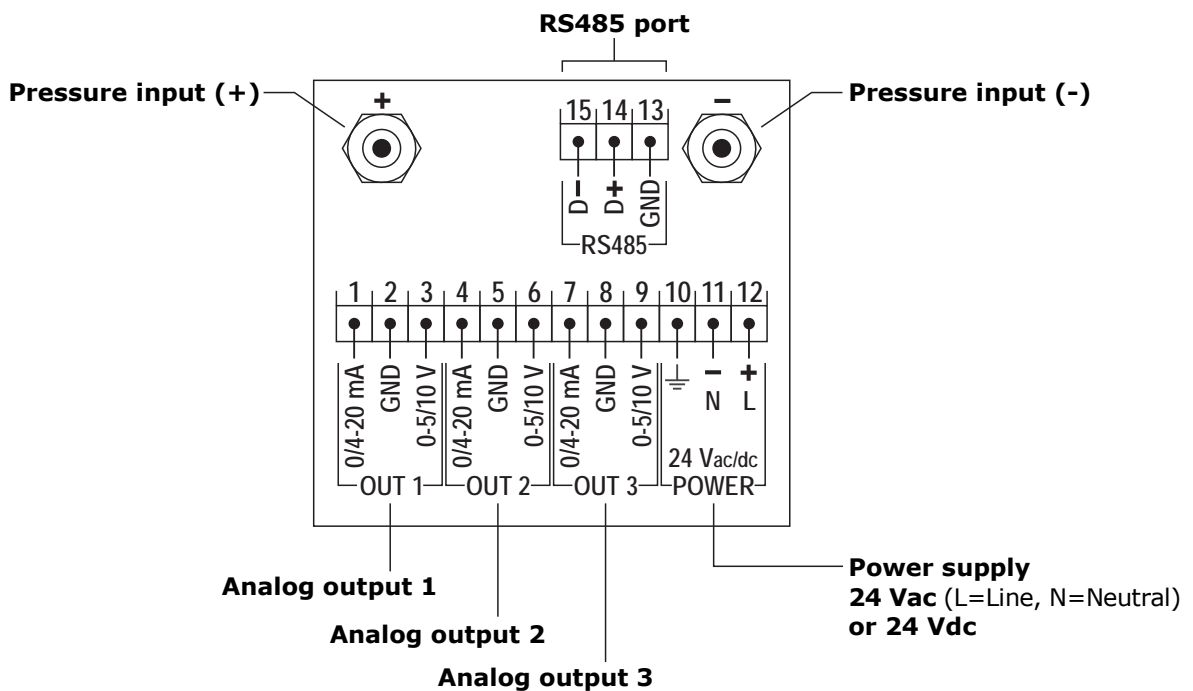

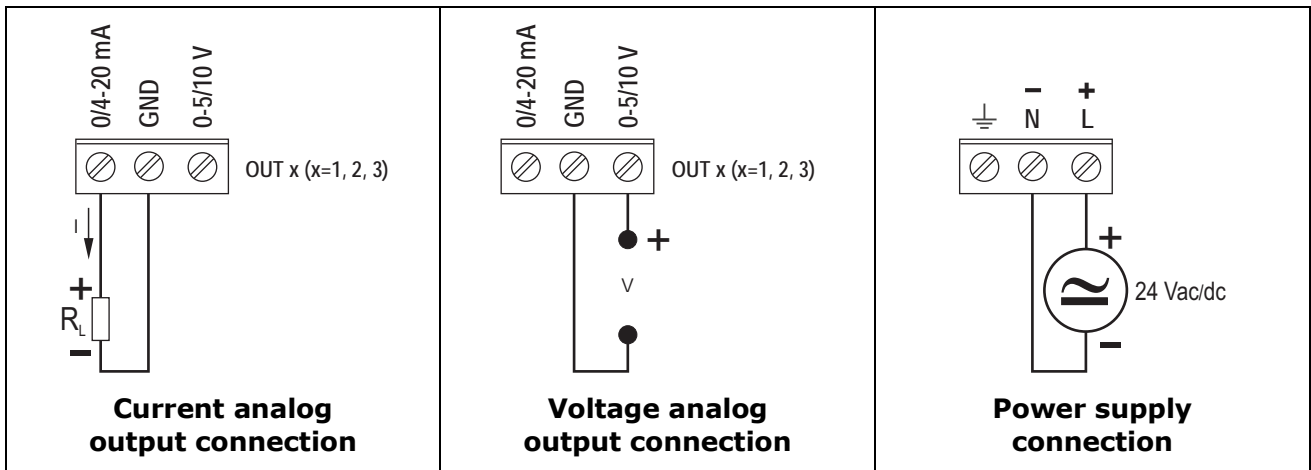

The three analog outputs are associated with the quantities of index CH1, CH2 and CH3 set in the F200 menu via the front keyboard of the instrument (see chapter 7) or via the HD35AP-S software.

The current analog output and the voltage analog output of the same channel (1, 2 or 3) are associated with the same quantity.

The RS485 connection is shown below.

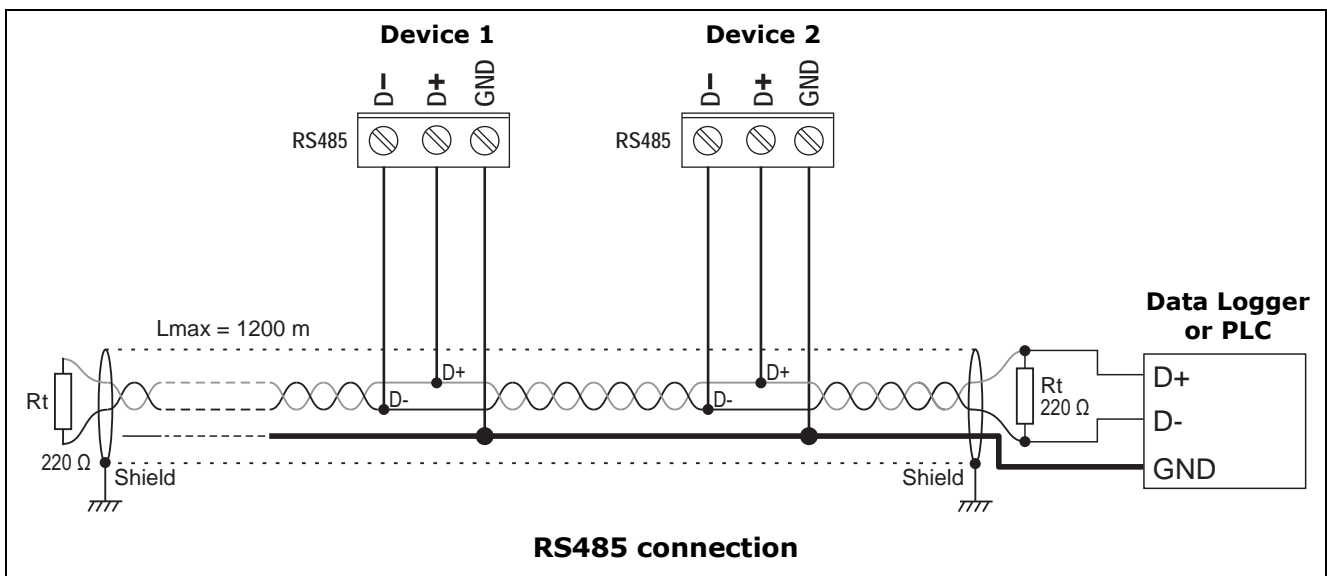

Connect any combined temperature and relative humidity probe to the 8-pole M12 connector on the bottom of the housing.

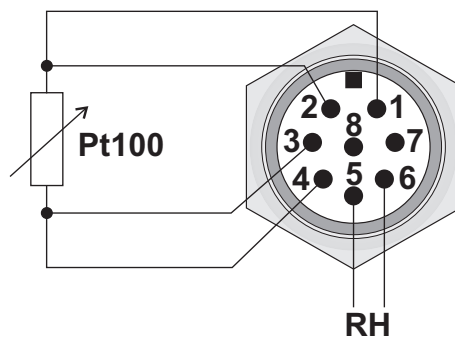

Pinout of the external side of the male M12 connector of the transmitter

3.1 CONFIGURATION

The operating parameters of the instrument can be configured in various way:

- Via front keyboard (see chapter 7).
- Via the HD35AP-S application software, connecting the instrument to the PC via USB.
- Via the Modbus-RTU protocol and the RS485 connection (see chapter 8).

The HD35AP-S application software is downloadable from Delta OHM website For the use of the application software, see the corresponding instructions.

4 ALARMS

For each detected quantity, two alarm thresholds can be set by the user. The alarm is generated if the measured value falls below the lower threshold or rises above the upper threshold.

Exceeding a threshold is signaled:

- acoustically, by means of the internal buzzer (if enabled);
- visually, by lighting the alarm LEDs on the front panel (only for the three measurements associated with the analog outputs);

An alarm hysteresis and a delay in the generation of the alarm can be configured for each detected quantity.

The amplitude of the hysteresis is in percentage (0...100%) of the difference between the two alarm thresholds. For example, if the hysteresis is 2% (default value), the lower threshold is 10 °C and the upper threshold is 60 °C, the hysteresis in °C is equal to $(60-10) \times 2 / 100 = 1 \text{ °C}$.

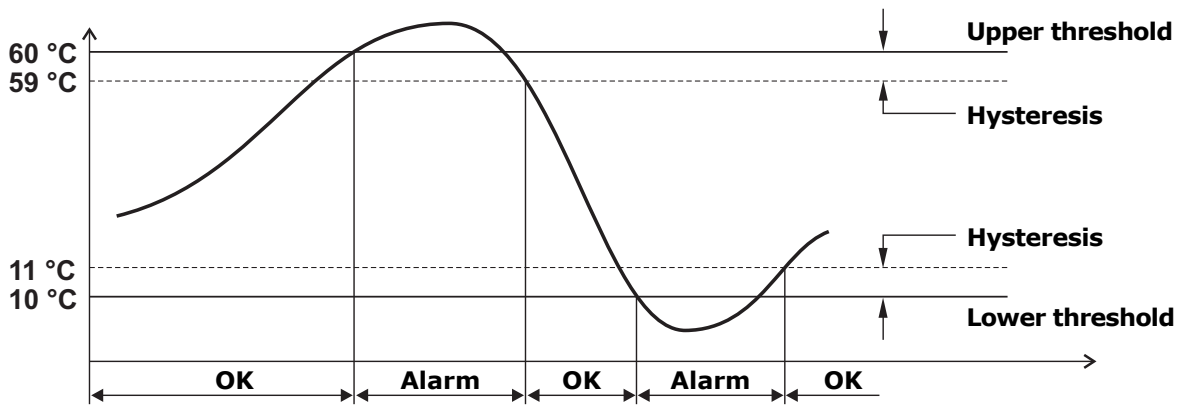

The alarm is generated after the set delay time or immediately if the "no delay" option is selected (default). If the alarm condition disappears before the delay time has elapsed, the alarm is not generated.

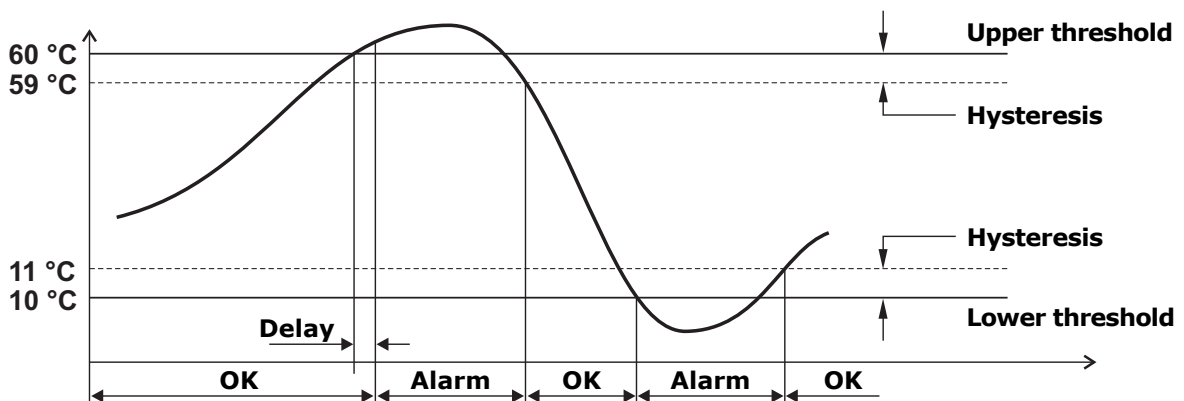

Enabling the Buzzer *Latch* option, the buzzer continues to sound even after the alarm condition has ceased.

In the event of an alarm in progress with the buzzer active, the buzzer can be silenced for a configurable time. Once the set time has elapsed, the buzzer will resume sounding

or not depending on whether the alarm condition is still present or not.

The following example shows the silencing of the buzzer with *Latch* option disabled.

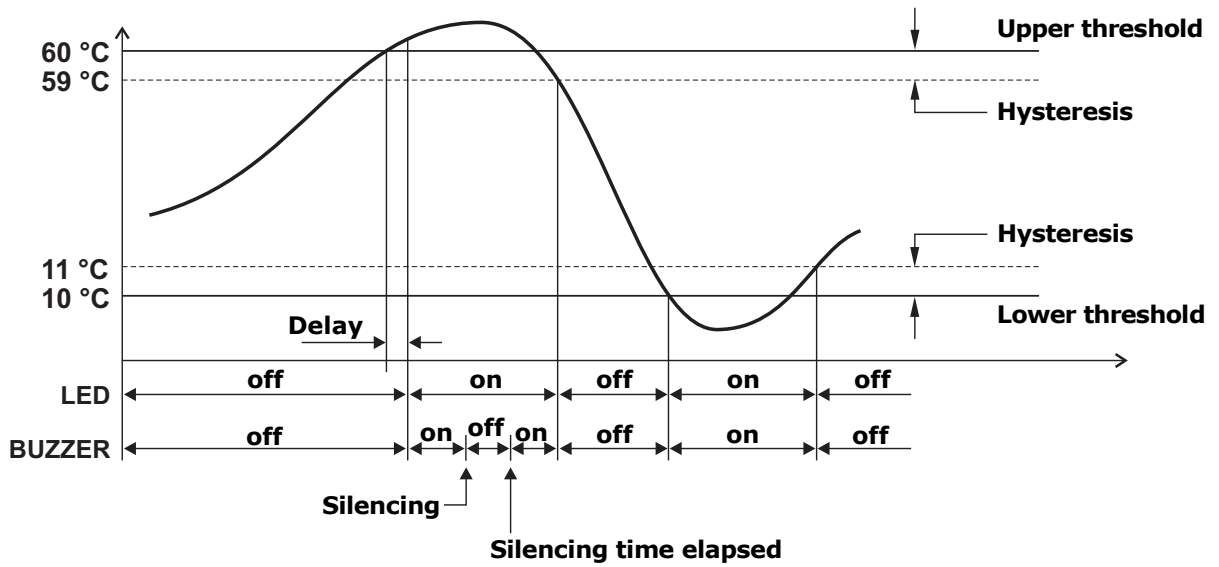

The following example shows the silencing of the buzzer with *Latch* option enabled.

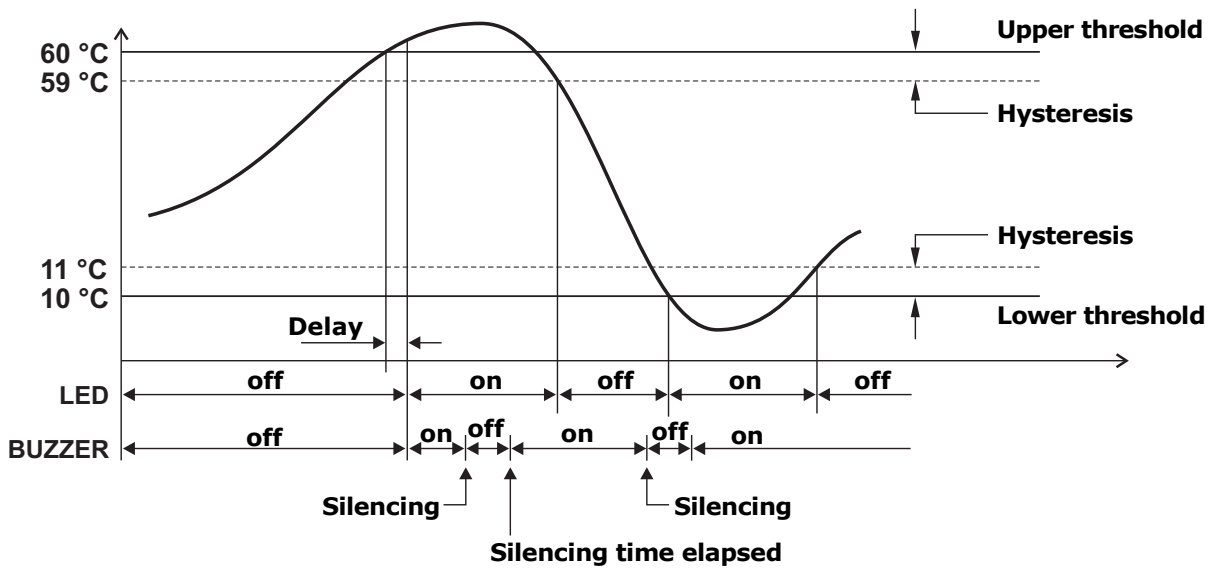

5 STATISTICAL FUNCTIONS

The instrument calculates and displays the maximum (MAX), minimum (MIN) and average (AVG) value of the detected measurements.

In order to display the statistical information, press **FUNC/▼**: the instrument shows the maximum value of the displayed quantity. To scroll the maximum values of the various quantities use the **▲** key.

By pressing **FUNC/▼** again, the instrument shows the minimum value of the displayed quantity. By pressing **FUNC/▼** again, the instrument shows the average value of the displayed quantity.

By pressing **FUNC/▼** once more, the instrument asks if the calculation of the statistical values is to be reset (FUNC CLR). Select *YES* or *nO* using **▼/▲** keys, then confirm with the **MENU/↵** key.

6 CALIBRATION

The instrument calibrates automatically at regular intervals (default 60 minutes, the interval is configurable) the zero of the differential pressure, temporarily disconnecting the pressure inputs through an internal solenoid valve.

Via the Fb00 menu (see chapter 7) it is possible to perform a manual calibration in one or two points. In order to perform manual calibration, it is necessary to unscrew the two front caps that cover the calibration inputs. To perform zero calibration (Fb05 in the menu), leave both inputs open. To perform calibration at non-zero values (gain calibration, Fb08 in the menu), connect the front inputs to a low differential pressure generator.

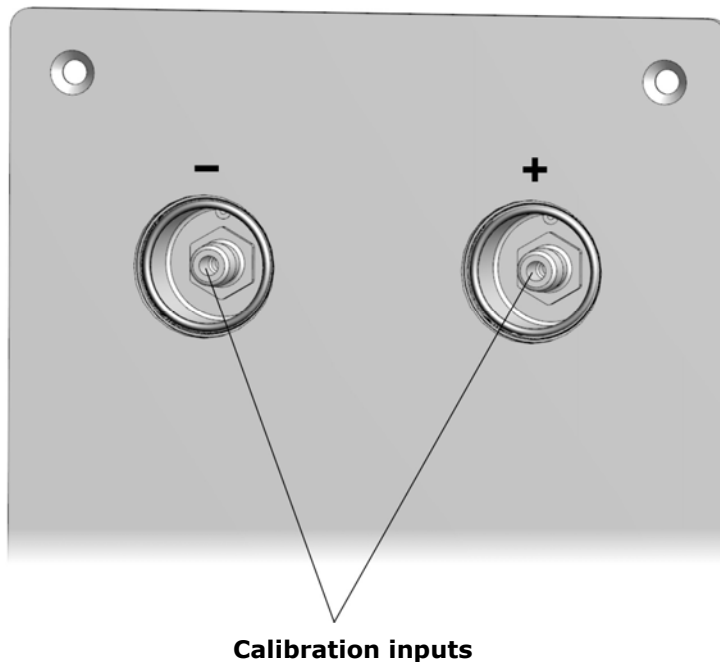

The differential pressure zero calibration is also possible via the Modbus Coil register with address 72 (see chapter 8).

At the end of the calibration or verification, firmly screw the front caps so that the seal is tight and the inputs are not affected by the external pressure.

Via the Fb00 menu it is also possible to calibrate the relative humidity sensor of the combined temperature and relative humidity probe at points 33% RH and 75% RH.

Warning: the optional combined relative humidity and temperature probe must be calibrated in line with the instrument. If the probe is ordered with the instrument, the probe is already factory calibrated. If the probe is ordered later, the calibration must be performed by the user via the Fb00 menu.

7 MENU

The menu accessible via the front keyboard allows displaying the instrument information and changing operating parameters. The menu is structured in levels, with main categories and submenus.

To access the menu, you need to enter the **user password** (configurable through the appropriate menu item) or the **administrator password** (supplied with the instrument and not editable). Entering the user password makes some settings not changeable.

The instrument exits automatically the menu if no key is pressed for 3 minutes. After exiting the menu, the password remains active for a few minutes, during which you may enter the menu again without re-entering the password. It is possible to exit the menu by disabling immediately the password by performing a password level reset in the *Password* menu.

To access a menu parameter, proceed as follows:

1. Press **MENU**, the first digit of the password will blink.
2. Using $\blacktriangledown/\blacktriangle$ keys, set the first digit and confirm (**MENU/↵** key), the second digit of the password will blink. Set the remaining digits in the same way.
3. Using $\blacktriangledown/\blacktriangle$ keys, select a main category in the menu and confirm (**MENU/↵** key).
4. If the selected main category has a submenu, select the desired item using $\blacktriangledown/\blacktriangle$ keys and confirm (**MENU/↵** key).
5. Using $\blacktriangledown/\blacktriangle$ keys, select the desired parameter: the parameter current setting is displayed.
6. To change the selected parameter, if allowed, press **MENU/↵**, the parameter setting blinks. Use $\blacktriangledown/\blacktriangle$ keys to change the setting, then confirm (**MENU/↵** key). You can fast forward by keeping \blacktriangledown or \blacktriangle key depressed.

To exit the main menu or a sub menu, press ESC key.

If it is not allowed to change a parameter, the notice N/A (Not Available) will appear when trying to change it.

Menu main category

F100 (DEV INFO): instrument general information

F200 (MEAS MENU): selection of the quantities to be detected

F300 (DISP LOOP VIEW): selection of the quantities to be displayed cyclically

F400 (ALRM MENU): setting of the alarms

F500 (UNIT MEAS MENU): units of measurement

F600 (LOG MENU): logging settings

F700 (AN OUT MENU): setting of the analog outputs

F800 (MODBUS MENU): Modbus settings

F900 (CLK MENU): clock settings

FA00 (PSW MENU): password settings

Fb00 (CAL MENU): calibration settings

F100 submenu (DEV INFO)

Instrument general information.

- F101:** model
- F102:** serial number
- F103:** user code
- F104:** group name
- F105:** firmware version
- F106:** firmware date
- F107:** factory calibration date
- F108:** user calibration date
- F109:** type of calibration in use (factory or user)
- F110:** external probe serial number

F200 submenu (MEAS MENU)

Selection and sorting of the quantities to be detected.

- F201:** temperature measurement index {CH1...CH6, default=CH2}
- F202:** relative humidity measurement index {CH1...CH6, default=CH3}
- F203:** Dew Point measurement index {CH1...CH6, default=CH4}
- F204:** Absolute humidity measurement index {CH1...CH6, default=CH5}
- F205:** Wet bulb temperature measurement index {CH1...CH6, default=CH6}
- F206:** differential pressure measurement index {CH1...CH6, default=CH1}

Set a measurement to *OFF* to exclude it.

F300 submenu (DISP LOOP VIEW)

Selection of the quantities to be displayed cyclically.

Note: in the F300 submenu, only the quantities to be detected appear, in the order set in the F200 submenu.

- F301:** quantity of index 1 {On/OFF, default=On}
- F302:** quantity of index 2 {On/OFF, default=On}
- F303:** quantity of index 3 {On/OFF, default=On}
- F304:** quantity of index 4 {On/OFF, default=OFF}
- F305:** quantity of index 5 {On/OFF, default=OFF}
- F306:** quantity of index 6 {On/OFF, default=OFF}

F400 submenu (ALRM MENU)

Setting of the alarms.

Note: in the F400 submenu, the quantities appear in the order set in the F200 submenu.

- F408:** period, in seconds, of the beep emitted by the buzzer {1...3600, default=2}
- F409:** duration, in seconds, of the beep emitted by the buzzer {0.1...20, default=1.0}
- F410: alarm of the quantity of index 1**
 - F411:** lower alarm threshold
 - F412:** lower alarm threshold enabling {On/OFF, default=On}

- F413:** upper alarm threshold
- F414:** upper alarm threshold enabling {On/OFF, default=On}
- F415:** alarm hysteresis in % of the difference between the two alarm thresholds {0...100 %, default=2%}
- F416:** delay time in signaling the alarm {max. 960 min, default=0}
- F417:** buzzer enabling {On/OFF, default=OFF}
- F418:** buzzer "Latch" function enabling {On/OFF, default=OFF}
- F419:** buzzer silencing time, in minutes {0...1080, default=0}

.
.
.

F460: alarm of the quantity of index 6

- F461:** lower alarm threshold
- F462:** lower alarm threshold enabling {On/OFF, default=On}
- F463:** upper alarm threshold
- F464:** upper alarm threshold enabling {On/OFF, default=On}
- F465:** alarm hysteresis in % of the difference between the two alarm thresholds {0...100 %, default=2%}
- F466:** delay time in signaling the alarm {max. 960 min, default=0}
- F467:** buzzer enabling {On/OFF, default=OFF}
- F468:** buzzer "Latch" function enabling {On/OFF, default=OFF}
- F469:** buzzer silencing time, in minutes {0...1080, default=0}

F500 submenu (UNIT MEAS MENU)

Units of measurement.

- F501:** temperature unit of measurement {°C/°F, default=°C}
- F502:** differential pressure unit of measurement {hPa / kPa / atm / mmHg / mmH₂O / inHg / inH₂O / (kgf /cm²) / PSI / mbar / bar / Pa, default=Pa}

F600 submenu (LOG MENU)

Logging settings.

- F601:** logging enabling/disabling {On/OFF, default=On}
- F602:** choice between cyclical management (the new data overwrite the old ones when the memory is full) or non-cyclical management (logging stops when the memory is full) of the instrument internal memory {YES=cyclical management / NO=non-cyclical management, default=YES}
- F603:** logging interval (if it is higher than the measuring interval, the average of the measurements acquired during the interval will be stored) {default=30 s}
- F604:** measurements acquisition interval {default=1 s}. If a value higher than the logging interval is set, the measurements will be detected with interval equal to the logging interval.
- F605:** deletion of all stored measurements from the instrument memory {YES/nO}

F700 submenu (AN OUT MENU)

Setting of the analog outputs.

F710: analog output 1

F711: 0-20 mA / 4-20 mA selection for the current output {default=4-20 mA}

F712: 0-5 V / 0-10 V selection for the voltage output {default=0-10 V}

F713: value of the quantity associated with the analog output corresponding to 0/4 mA and 0 V {default=-100 Pa}

F714: value of the quantity associated with the analog output corresponding to 20 mA and 5/10 V {default=+100 Pa}

F715: analog output test mode. The current output goes to the value entered. Set OFF to exit the test mode.

F716: analog output test mode. The voltage output goes to the value entered. Set OFF to exit the test mode.

F720: analog output 2

F721: 0-20 mA / 4-20 mA selection for the current output {default=4-20 mA}

F722: 0-5 V / 0-10 V selection for the voltage output {default=0-10 V}

F723: value of the quantity associated with the analog output corresponding to 0/4 mA and 0 V {default=0.0 °C}

F724: value of the quantity associated with the analog output corresponding to 20 mA and 5/10 V {default=100.0 °C}

F725: analog output test mode. The current output goes to the value entered. Set OFF to exit the test mode.

F726: analog output test mode. The voltage output goes to the value entered. Set OFF to exit the test mode.

F730: analog output 3

F731: 0-20 mA / 4-20 mA selection for the current output {default=4-20 mA}

F732: 0-5 V / 0-10 V selection for the voltage output {default=0-10 V}

F733: value of the quantity associated with the analog output corresponding to 0/4 mA and 0 V {default=0.0 %RH}

F734: value of the quantity associated with the analog output corresponding to 20 mA and 5/10 V {default=100.0 %RH}

F735: analog output test mode. The current output goes to the value entered. Set OFF to exit the test mode.

F736: analog output test mode. The voltage output goes to the value entered. Set OFF to exit the test mode.

F800 submenu (MODBUS MENU)

Modbus settings.

F801: Modbus address {1...247, default=1}

F802: RS485 baud rate in kbps {9.6 / 19.2 / 38.4 / 57.6 / 115.2, default=19.2}

F803: RS485 communication mode {8N1 / 8N2 / 8E1 / 8E2 / 8O1 / 8O2, default=8E1}

F804: waiting of 3.5 characters after transmission with Modbus protocol {nO=violate protocol and go in receiving mode right after transmission / YES=respect protocol and wait 3.5 characters after transmission, default=nO}

F805: enabling of the password for changing the configuration via Modbus {On/OFF, default=OFF}

F900 submenu (CLK MENU)

Clock settings.

F901: year

F902: month

F903: day

F904: hour

F905: minutes

F906: enabling of the automatic synchronization of the internal clock with a reference server {On/OFF, default=OFF}

F907: time zone {default=0}

FA00 submenu (PSW MENU)

Password settings.

FA01: exits the menu and deactivates immediately the password {YES/nO}. The password will not remain active for some minutes as it normally happens when exiting the menu: you will need to re-enter the password even if you re-access immediately the menu.

FA02: setting of the user-level password {default=0000}

FA03: locking of the instrument keyboard {YES/nO, default=nO}. If the keyboard is locked, keep the **MENU/↵** key pressed for 7 seconds to unlock it.

Fb00 submenu (CAL MENU)

Calibration settings.

Fb03: relative humidity sensor calibration at 75%RH

Fb04: relative humidity sensor calibration at 33%RH

Fb05: differential pressure calibration at zero

Fb06: enabling of the differential pressure auto-calibration at zero {On/OFF, default=On}

Fb07: interval, in minutes, of the differential pressure auto-calibration at zero {5...360, default=60}

Fb08: differential pressure second calibration point (in Pa)

Fb09: reset of the differential pressure second calibration point

Fb10: type of calibration used {FACT=factory / USEr=user, default=FACT}

8 MODBUS

The device general information can be read through the function code **0x2B/0x0E**:

- Manufacturer (Delta OHM)
- Model
- Firmware version

The complete list of MODBUS registers is shown below. If you try to read a register that is not present, the instrument returns the fixed value 32767. The list of the available registers can be downloaded in the PC using the function " *Download the list of MODBUS registers of the device* " included in the *Settings* sections of HD35AP-S software (see software instructions).

The following conventions have been used in the tables:

- Type: **b** = bit, **B** = 8 bits (Byte), **W** = 16 bits without sign (Word), **SW** = 16 bits with sign
- **(x10)** = decimal value expressed as an integer (e.g., if the content of the register is 184, the value is to be intended as 18,4).
- **(x100)** = centesimal value expressed as an integer (e.g., if the content of the register is 500, the value is to be intended as 5,00).

The commands for requesting units of measurement return an index according to the correspondence indicated in the table below:

Indexes of the units of measurement

Index	Unit of meas.	Index	Unit of meas.	Index	Unit of meas.	Index	Unit of meas.	Index	Unit of meas.
0	°C	13	inchHg	26	J/m ²	39	inch	52	l/min
1	°F	14	inchH ₂ O	27	μJ/cm ²	40	counts	53	gallon/min
2	%UR	15	kgf/cm ²	28	V	41	mm/h	54	m ³ /min
3	g/m ³	16	PSI	29	mV	42	inch/h	55	m ³ /h
4	g/kg	17	m/s	30	mA	43	counts/h	56	μmol/(m ² s)
5	mbar	18	km/h	31	ppm	44	mW/m ²	57	mm/day
6	bar	19	ft/s	32	Hz	45	m	58	kV
7	Pa	20	mph	33	%	46	s	59	A
8	hPa	21	knot	34	degrees	47	μW/lumen	60	kA
9	kPa	22	W/m ²	35	lux	48	dB		
10	atm	23	μW/cm ²	36	m ² /s	49	dBA		
11	mmHg	24	Wh/m ²	37	g (*)	50	kWh		
12	mmH ₂ O	25	kWh/m ²	38	mm	51	l/s	255	Not defined

(*) Gravity acceleration

Discrete Inputs - Read-only parameters

Address	Type	Discrete Input description
7	b	If 1, at least a quantity is in alarm.

Coils - Read/Write parameters

Address	Type	Coil description
0	b	Receiving mode after transmission with Modbus protocol: 0=violate protocol and go in receiving mode right after transmission 1=respect protocol and wait 3.5 characters after transmission
1	b	Logging status: 0=active, 1=inactive
2	b	Logging mode: 0=non cyclic, 1=cyclic
3	b	Set 1 to delete the device logging memory. Bit zeroing is automatic.
9	b	Protection of configuration with password: 0=no, 1=yes Changing the parameter requires the Administrator password (see Holding Register 10036).
23	b	Enabling of the lower alarm threshold for the quantity #1: 0= disabled, 1= enabled
24	b	Enabling of the lower alarm threshold for the quantity #2: 0= disabled, 1= enabled
25	b	Enabling of the lower alarm threshold for the quantity #3: 0= disabled, 1= enabled
26	b	Enabling of the lower alarm threshold for the quantity #4: 0= disabled, 1= enabled
27	b	Enabling of the lower alarm threshold for the quantity #5: 0= disabled, 1= enabled
28	b	Enabling of the lower alarm threshold for the quantity #6: 0= disabled, 1= enabled
35	b	Enabling of the upper alarm threshold for the quantity #1: 0= disabled, 1= enabled
36	b	Enabling of the upper alarm threshold for the quantity #2: 0= disabled, 1= enabled
37	b	Enabling of the upper alarm threshold for the quantity #3: 0= disabled, 1= enabled
38	b	Enabling of the upper alarm threshold for the quantity #4: 0= disabled, 1= enabled
39	b	Enabling of the upper alarm threshold for the quantity #5: 0= disabled, 1= enabled
40	b	Enabling of the upper alarm threshold for the quantity #6: 0= disabled, 1= enabled
47	b	Enabling of the buzzer for the quantity #1: 0= disabled, 1=enabled
48	b	Enabling of the buzzer for the quantity #2: 0= disabled, 1=enabled
49	b	Enabling of the buzzer for the quantity #3: 0= disabled, 1=enabled
50	b	Enabling of the buzzer for the quantity #4: 0= disabled, 1=enabled
51	b	Enabling of the buzzer for the quantity #5: 0= disabled, 1=enabled
52	b	Enabling of the buzzer for the quantity #6: 0= disabled, 1=enabled
59	b	Enabling of the buzzer "Latch" function for the quantity #1: 0= disabled, 1=enabled
60	b	Enabling of the buzzer "Latch" function for the quantity #2: 0= disabled, 1=enabled
61	b	Enabling of the buzzer "Latch" function for the quantity #3: 0= disabled, 1=enabled
62	b	Enabling of the buzzer "Latch" function for the quantity #4: 0= disabled, 1=enabled
63	b	Enabling of the buzzer "Latch" function for the quantity #5: 0= disabled, 1=enabled

Address	Type	Coil description
64	b	Enabling of the buzzer "Latch" function for the quantity #6: 0= disabled, 1=enabled
71	b	Type of calibration used: 0=factory, 1=user
72	b	Set 1 to carry out the zero calibration of the differential pressure. Bit zeroing is automatic.
73	b	Enabling of the auto-calibration of the zero of the differential pressure: 0=disabled, 1=enabled

Input Registers - Read-only parameters

Address	Type	Input Register description
Measured values and status of measurement alarms		
2	SW	RELATIVE HUMIDITY in % (x10).
3	B	Relative humidity alarm: 0=OFF, 1=lower threshold alarm, 2=higher threshold alarm.
4	SW	DEW POINT in the set measurement unit (x10).
5	B	Dew Point alarm: 0=OFF, 1=lower threshold alarm, 2=higher threshold alarm.
10	SW	ABSOLUTE HUMIDITY in g/m ³ (x10).
11	B	Absolute humidity alarm: 0=OFF, 1=lower threshold alarm, 2=higher threshold alarm.
12	SW	WET BULB TEMPERATURE in the set measurement unit (x10).
13	B	Wet bulb temperature alarm: 0=OFF, 1=lower threshold alarm, 2=higher threshold alarm.
60	SW	DIFFERENTIAL PRESSURE in the set measurement unit (the multiplier depends on the set unit).
61	B	Differential pressure alarm: 0=OFF, 1=lower threshold alarm, 2=higher threshold alarm.
174	SW	TEMPERATURE with 4-wire Pt100 sensor of the T/RH combined probe in the set measurement unit (x100).
175	B	Alarm for temperature with 4-wire Pt100 sensor of the T/RH combined probe: 0=OFF, 1=lower threshold alarm, 2=higher threshold alarm.
Measurement units and resolution		
5004	W	DEW POINT measurement unit: 0=°C, 1=°F.
5012	W	WET BULB TEMPERATURE measurement unit: 0=°C, 1=°F.
5084	W	DIFFERENTIAL PRESSURE measurement unit: see the table of indexes
5085	SW	DIFFERENTIAL PRESSURE resolution: ..., -2=100, -1=10, 0=1, 1=0.1, 2=0.01, ...
5174	W	Unit of measurement for TEMPERATURE with 4-wire Pt100 sensor of the T/RH combined probe: 0=°C, 1=°F.
General information		
10000	W	Year of last measurement.
10001	W	Month of last measurement.
10002	W	Day of last measurement.
10003	W	Hour of last measurement.
10004	W	Minutes of last measurement.
10005	W	Seconds of last measurement.
10013	W	Password level for the current connection: 0=no password, 1=user level, 2= administrator level

Holding Registers - Read/Write parameters

Address	Type	Holding Register description
Measurement alarm thresholds		
2	SW	RH lower alarm threshold in % (x10).
3	SW	RH higher alarm threshold in % (x10).
4	SW	DEW POINT lower alarm threshold in the set measurement unit (x10).
5	SW	Dew point higher alarm threshold in the set measurement unit (x10).
10	SW	ABSOLUTE HUMIDITY lower alarm threshold in g/m ³ (x10).
11	SW	Absolute humidity higher alarm threshold in g/m ³ (x10).
12	SW	WET BULB TEMPERATURE lower alarm threshold in the set measurement unit (x10).
13	SW	Wet bulb temperature higher alarm threshold in the set measurement unit (x10).
60	SW	DIFFERENTIAL PRESSURE lower alarm threshold in the set measurement unit (the multiplier depends on the set unit).
61	SW	Differential pressure higher alarm threshold in the set measurement unit (the multiplier depends on the set unit).
174	SW	Lower alarm threshold for TEMPERATURE with 4-wire Pt100 sensor of the T/RH combined probe in the set measurement unit (x100).
175	SW	Higher alarm threshold for temperature with 4-wire Pt100 sensor of the T/RH combined probe in the set measurement unit (x100).
General information		
da 10000 a 10019	B	User code with ASCII codification. Acceptable values are in the set {32,...,126}.
10020	W	Current year
10021	W	Current month
10022	W	Current day
10023	W	Current hour
10024	W	Current minute
10025	W	Current second
10026	W	Measurement interval: 0=1s, 1=2s, 2=5s, 3=10s, 4=15s, 5=30s, 6=1min, 7=2min, 8=5min, 9=10min, 10=15min, 11=30min, 12=1h
10027	W	Logging interval: 0=1s, 1=2s, 2=5s, 3=10s, 4=15s, 5=30s, 6=1min, 7=2min, 8=5min, 9=10min, 10=15min, 11=30min, 12=1h
10032	W	Temperature measurement unit: 0=°C, 1=°F
10034	W	Baud rate RS485: 0=9600, 1=19200, 3=38400 bit/s
10035	W	RS485 communication mode: 0=8N1, 1=8N2, 2=8E1, 3=8E2, 4=8O1, 5=8O2
10036	W	Password to be supplied to enable configuration change commands. The reading provides the fixed value 32768.
da 10037 a 10046	B	Device group with ASCII codification. Acceptable values are in the set {32,...,126}.
10049	W	Differential pressure unit of measurement: see the table of indexes
10052	W	Setting of the quantities to be displayed in the automatic viewing cycle. Set the i-th bit (starting from LSB) to 1 if you wish to include the i-th quantity in the viewing cycle. <i>Example:</i> if 1=Temp., 2=RH, 3=Td, 4=Diff.Press., 5=AH, 6=Tw, the register is set to 0000 0000 0001 0010, only the relative humidity (RH) and the absolute humidity (AH) will be displayed alternatively.
10064	W	Modbus address

Address	Type	Holding Register description
10065	W	Buzzer silencing time, in minutes, for the quantity #1
10066	W	Buzzer silencing time, in minutes, for the quantity #2
10067	W	Buzzer silencing time, in minutes, for the quantity #3
10068	W	Buzzer silencing time, in minutes, for the quantity #4
10069	W	Buzzer silencing time, in minutes, for the quantity #5
10070	W	Buzzer silencing time, in minutes, for the quantity #6
10077	B	Current range of the analog output 1: 0=0...20 mA, 1=4...20 mA
10078	B	Voltage range of the analog output 1: 0=0...10 V, 1=0...5 V
10079	SW	Value of the quantity associated with the analog output 1 corresponding to 0/4 mA and 0 V
10080	SW	Value of the quantity associated with the analog output 1 corresponding to 20 mA and 5/10 V
10081	W	Analog output 1 test register: the current output goes to the value, in tenths of mA, entered in the register (e.g., enter 120 for 12.0 mA). Set -1 to exit the test mode.
10082	W	Analog output 1 test register: the voltage output goes to the value, in tenths of V, entered in the register (e.g., enter 50 for 5.0 V). Set -1 to exit the test mode.
10083	B	Current range of the analog output 2: 0=0...20 mA, 1=4...20 mA
10084	B	Voltage range of the analog output 2: 0=0...10 V, 1=0...5 V
10085	SW	Value of the quantity associated with the analog output 2 corresponding to 0/4 mA and 0 V
10086	SW	Value of the quantity associated with the analog output 2 corresponding to 20 mA and 5/10 V
10087	W	Analog output 2 test register: the current output goes to the value, in tenths of mA, entered in the register (e.g., enter 120 for 12.0 mA). Set -1 to exit the test mode.
10088	W	Analog output 2 test register: the voltage output goes to the value, in tenths of V, entered in the register (e.g., enter 50 for 5.0 V). Set -1 to exit the test mode.
10089	B	Current range of the analog output 3: 0=0...20 mA, 1=4...20 mA
10090	B	Voltage range of the analog output 3: 0=0...10 V, 1=0...5 V
10091	SW	Value of the quantity associated with the analog output 3 corresponding to 0/4 mA and 0 V
10092	SW	Value of the quantity associated with the analog output 3 corresponding to 20 mA and 5/10 V
10093	W	Analog output 3 test register: the current output goes to the value, in tenths of mA, entered in the register (e.g., enter 120 for 12.0 mA). Set -1 to exit the test mode.
10094	W	Analog output 3 test register: the voltage output goes to the value, in tenths of V, entered in the register (e.g., enter 50 for 5.0 V). Set -1 to exit the test mode.
10095	W	Period, in minutes, of the auto-calibration of the zero of the differential pressure
da 20000 a 20011	B	User code with ASCII codification of the quantity #1.
da 20012 a 20023	B	User code with ASCII codification of the quantity #2.
da 20024 a 20035	B	User code with ASCII codification of the quantity #3.

Address	Type	Holding Register description
da 20036 a 20047	B	User code with ASCII codification of the quantity #4.
da 20048 a 20059	B	User code with ASCII codification of the quantity #5.
da 20060 a 20071	B	User code with ASCII codification of the quantity #6.
Measurement alarm hysteresis and delay time		
30002	B	RH alarm hysteresis in % (x10).
30003	B	RH alarm delay time in seconds.
30004	B	DEW POINT alarm hysteresis in the set measurement unit (x10).
30005	B	Dew point alarm delay time in seconds.
30010	B	ABSOLUTE HUMIDITY alarm hysteresis in g/m ³ (x10).
30011	B	Absolute humidity alarm delay time in seconds.
30012	B	WET BULB TEMPERATURE alarm hysteresis in the set measurement unit (x10).
30013	B	Wet bulb temperature alarm delay time in seconds.
30060	B	DIFFERENTIAL PRESSURE alarm hysteresis in the set measurement unit (the multiplier depends on the set unit).
30061	B	Differential pressure alarm delay time in seconds.
30174	B	Alarm hysteresis for TEMPERATURE with 4-wire Pt100 sensor of the T/RH combined probe in the set measurement unit (x100).
30175	B	Alarm delay time for temperature with 4-wire Pt100 sensor of the T/RH combined probe in seconds.

9 TECHNICAL CHARACTERISTICS

Differential Pressure	
Sensor	Piezoresistive
Measuring range	± 100 Pa
Resolution	0.1 Pa
Accuracy	± (0.8% of measure + 0.5) Pa @ 0...50 °C
Zero drift	Self-calibration
Units of measurement	Pa, mmH ₂ O, mbar, inH ₂ O, mmHg, hPa
Connection	Ø 6 mm barbed inputs
Overpressure	50 kPa
Type of fluid	Air and neutral gases
Temperature (optional)	
Sensor	4-wire Pt100
Measuring range	-40...+150 °C
Resolution	0.01 °C
Accuracy	1/3 DIN
Stability	0.1 °C/year
Relative Humidity (optional)	
Sensor	Capacitive
Measuring range	0...100 %RH
Resolution	0.1 %RH
Accuracy	± 1.8 %RH (0..85 %RH) / ± 2.5 %RH (85..100 %RH) @ T=15...35°C ± (2 + 1.5% of the measure)% @ T=remaining range
Sensor operating temperature	-20...+80 °C
Response time	T ₉₀ < 20 s (air speed = 2 m/s, without filter)
Temperature drift	±2% in all the operating temperature range
Stability	1%/year

General characteristics	
Display	Red electroluminescent
Keyboard	Yes (4 keys)
Configuration	Via front keys, USB and RS485 Modbus connection
Alarm	Buzzer on and LED lighting
Analog output	3 x 0/4...20 mA (active, max. load 500 Ω) or 3 x 0...5/10 V (min. load 10 k Ω) galvanically isolated
USB	Yes, HID type (no USB drivers) with front Mini-USB type B connector
RS485	Yes, with Slave Modbus-RTU protocol
Protocols	Proprietary, Modbus-RTU
Measuring interval	1, 2, 5, 10, 15, 30 s / 1, 2, 5, 10, 15, 30, 60 min
Logging interval	1, 2, 5, 10, 15, 30 s / 1, 2, 5, 10, 15, 30, 60 min
Internal memory	Circular management or stop logging if memory is full. Number of storable samples from 420,940 to 906,640 to depending on the number of quantities selected for logging.
Power supply	24 Vac / Vdc \pm 10%
Power consumption	5 W
Electrical connections	Screw terminal block (max. 1.5 mm ² / AWG16 cables)
Operating temperature	-10...+50 °C
Storage temperature	-10...+70 °C
Housing material	Stainless steel (AISI 316 front panel)
Weight	640 g approx.
Installation	Flush-mount
Protection degree	IP 65 (front panel, with protective cap on USB connector)

Dimensions (mm):

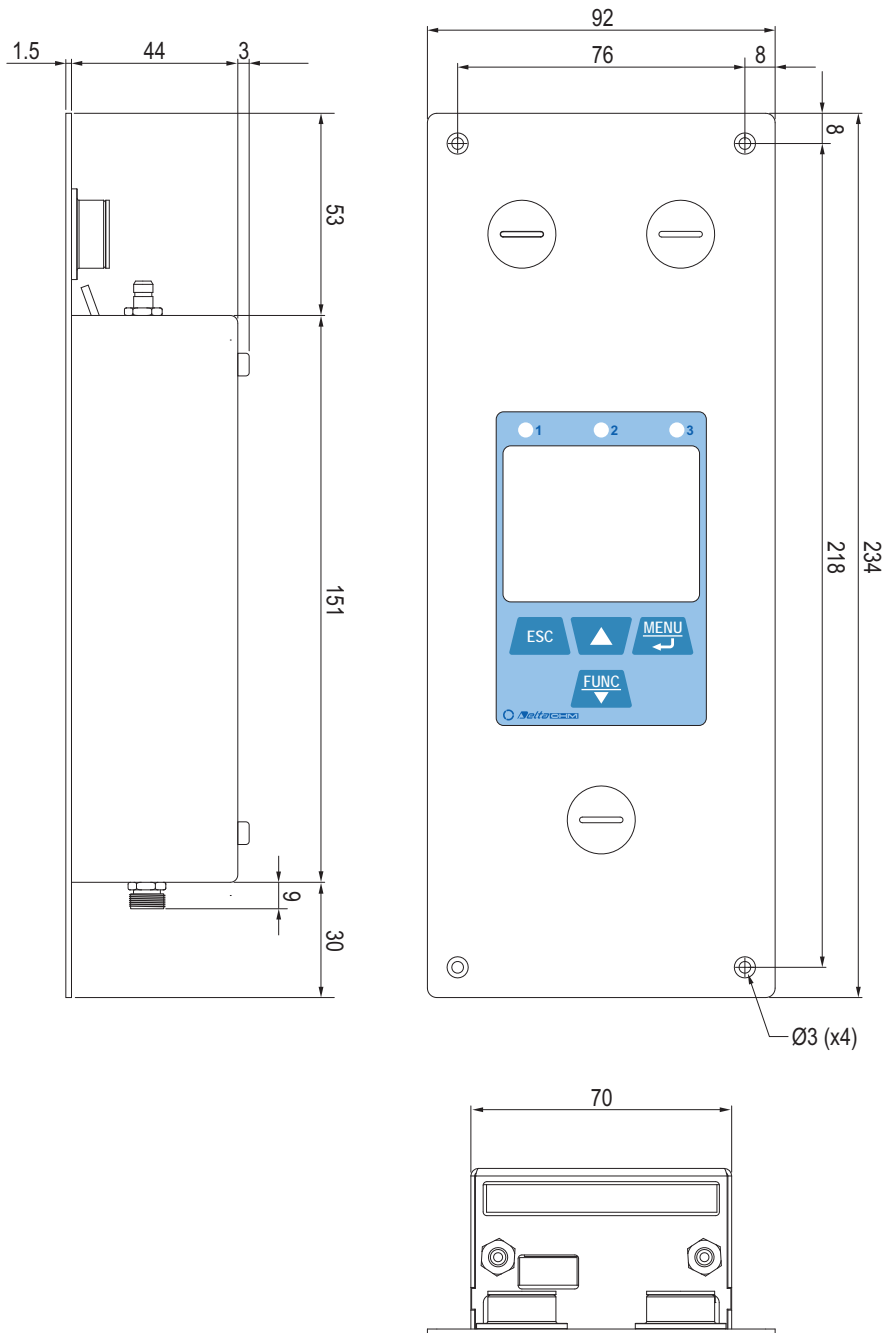

10 INSTRUMENT STORAGE

Conditions for storage of the instrument:

- Temperature: -10...+70 °C.
- Humidity: below 90 %RH no condensation.
- When storing, avoid places where:
 - humidity is high;
 - instrument is exposed to direct solar radiation;
 - instrument is exposed to high temperature source;
 - there are strong vibrations;
 - there is vapor, salt and/or corrosive gas.

11 SAFETY INSTRUCTIONS

General safety instructions

The instrument has been manufactured and tested in compliance with the safety standard EN61010-1:2010 "Safety requirements for electrical equipment for measurement, control and laboratory use" and left the factory in a safe and secure technical condition.

The proper operation and the operational safety of the instrument can be ensured only if all the regular security measures are observed as well as the specific measures described in this operating manual.

The proper operation and the operational safety of the instrument can be ensured only under the climatic conditions specified in this manual.

Do not use the instrument in places where there are:

- Rapid ambient temperature variations that may cause condensation.
- Corrosive or flammable gases.
- Direct vibrations, shocks to the instrument.
- High-intensity electromagnetic fields, static electricity.

If the instrument is moved from a cold environment to a hot one or vice versa, the formation of condensation might cause problems to its operation. In this case you need to wait for the instrument temperature to reach ambient temperature before operation.

User obligations

The user of the instrument must make sure that the following regulations and directives related to the handling of hazardous materials are fulfilled:

- European directives on safety and health at work.
- National regulations on safety and health at work.
- Accident prevention regulations.

12 PROBES AND ACCESSORIES ORDERING CODES

HP3517E... Temperature and relative humidity combined probe. Pt100 temperature sensor. Measuring range: 0...100 %RH, -40...+150 °C. 8-pole M12 female connector.

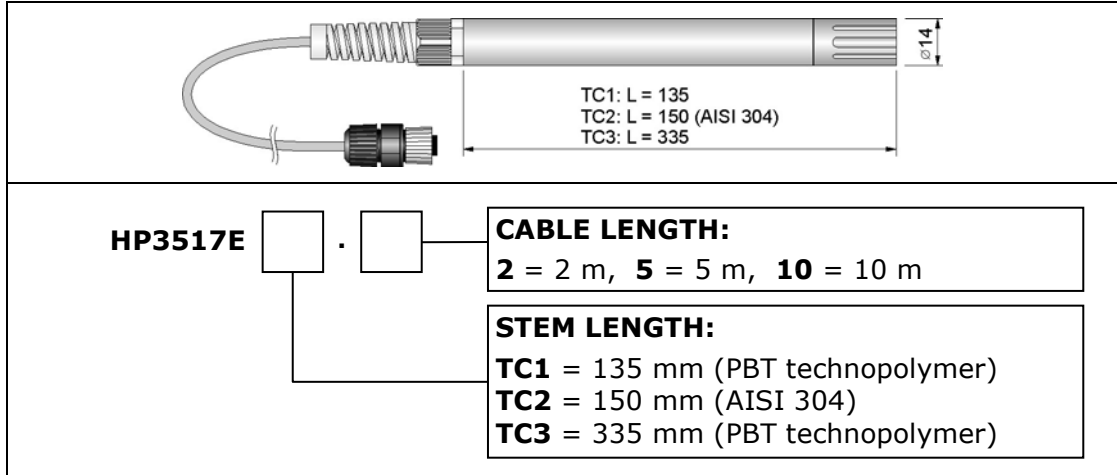

HD35AP-CFR21 Software option that adds to the features of the basic HD35AP-S software the management of the data in accordance with the **FDA 21 CFR part 11 recommendations**.

HD75 Saturated solution to check Relative Humidity probes at 75 % RH, includes ring adapter for 14 mm diameter probes, thread M12×1.

HD33 Saturated solution to check Relative Humidity probes at 33 % RH, includes ring adapter for 14 mm diameter probes, thread M12×1.

HD11 Saturated solution to check Relative Humidity probes at 11 % RH, includes ring adapter for 14 mm diameter probes, thread M12×1.

DELTA OHM metrology laboratories LAT N° 124 are ISO/IEC 17025 accredited by ACCREDIA for Temperature, Humidity, Pressure, Photometry / Radiometry, Acoustics and Air Velocity. They can supply calibration certificates for the accredited quantities.

NOTES

NOTES

NOTES

NOTES

WARRANTY

The manufacturer is required to respond to the "factory warranty" only in those cases provided by Legislative Decree 6 September 2005 - n. 206. Each instrument is sold after rigorous inspections; if any manufacturing defect is found, it is necessary to contact the distributor where the instrument was purchased from. During the warranty period (24 months from the date of invoice) any manufacturing defects found will be repaired free of charge. Misuse, wear, neglect, lack or inefficient maintenance as well as theft and damage during transport are excluded. Warranty does not apply if changes, tampering or unauthorized repairs are made on the product. Solutions, probes, electrodes and microphones are not guaranteed as the improper use, even for a few minutes, may cause irreparable damages.

The manufacturer repairs the products that show defects of construction in accordance with the terms and conditions of warranty included in the manual of the product. For any dispute, the competent court is the Court of Padua. The Italian law and the "Convention on Contracts for the International Sales of Goods" apply.

TECHNICAL INFORMATION

The quality level of our instruments is the result of the continuous product development. This may lead to differences between the information reported in the manual and the instrument you have purchased.

We reserves the right to change technical specifications and dimensions to fit the product requirements without prior notice.

DISPOSAL INFORMATION

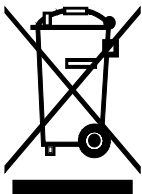

Electrical and electronic equipment marked with specific symbol in compliance with 2012/19/EU Directive must be disposed of separately from household waste. European users can hand them over to the dealer or to the manufacturer when purchasing a new electrical and electronic equipment, or to a WEEE collection point designated by local authorities. Illegal disposal is punished by law.

Disposing of electrical and electronic equipment separately from normal waste helps to preserve natural resources and allows materials to be recycled in an environmentally friendly way without risks to human health.

CE RoHS



senseca

Please note our new name:
Senseca Italy Srl
Via Marconi 5, 35030 Padua, Italy
Documents are in the process of being changed.